



e-joist®



ENGINEERED  
VENEEER LUM





ENGINEERED  
VENEER

e-beam®

st®

INATED

# CONTENTS

## 01

### e-joint

---

|  |   |
|--|---|
| Overview   | 1 |
| e-joint Design Information                           | 2 |
| Floor Joists Supporting Floor and Ceiling Loads Only | 3 |
| e-joint Construction Information                     | 4 |

## 05

### Installation Details

---

|                                 |    |
|---------------------------------|----|
| Bearing at Supports             | 5  |
| Support Details                 | 6  |
| Bracing and Blocking            | 7  |
| Ground Floor Framing            | 9  |
| Fixing to Supports              | 10 |
| Flange Notching and Web Cutting | 12 |
| Bracing and Tie Down            | 13 |

## 14

### Openings in Floors

---

## 16

### Cantilevers for Balconies (Non-Load Bearing)

---

## 18

### Determination of Roof Load Width

---

## 19

### Load Bearing Cantilevers

---

## 22

### Floor Joists Supporting Parallel Load Bearing Walls

---

|                      |    |
|----------------------|----|
| e-joint Floor Joists | 23 |
| e-beam Floor Joists  | 24 |

## 25

### Services Hole Guide

---

## 27

### e-joint Specification

---



ENGINEERED TO LOAD  
ENGINEERED TO LENGTH  
ENGINEERED TO LAST

e-joist®

END OF STORY



# 01 OVERVIEW

e-joist is the premier I-joist product available in Australia. e-joist has many advantages over traditional building products, including its uniformity of engineering properties, it's high strength to weight ratio and its availability in longer lengths.

e-joist is available in a range of depths and flange widths as presented below:

| Flange Width | Depths   |         |         |         |
|--------------|----------|---------|---------|---------|
|              | 200      | 240     | 300     | 360     |
| 45           | ej20045  | ej24045 | ej30045 |         |
| 63           | ej20063* | ej24063 | ej30063 | ej36063 |
| 90           | ej20090* | ej24090 | ej30090 | ej36090 |

**Note** e-joist sizes marked with an \* are not available in all Australian States. Check with your local Wesbeam office or approved Wesbeam distributor for available stock sizes.

e-joist is manufactured from sustainably sourced timbers, making it an environmentally sustainable resource.

## About e-joist

e-joist utilises a Laminated Veneer Lumber (LVL) flange and a structural web. Flanges are manufactured by laminating predominantly Maritime Pine veneer using phenolic adhesive in a continuous assembly in which the grain direction of all veneers runs longitudinally.

## Safety Data Sheets (SDS)

MSDS information on the LVL flange and web materials is available at [www.wesbeam.com](http://www.wesbeam.com)

## Use of e-joist Data

The Tables and other technical data provided in this publication are only applicable to e-joist manufactured by Wesbeam. This data should not be used for look-alike or substitute products. Use of the e-joist data for look-alike or substitute products can result in unsafe or unsatisfactory performance.

## Design Loads

These tables are designed to be used for residential housing only. For use in other applications, including flats, school buildings, offices, and a range of commercial applications, please refer to either the e-house suite of design software or Wesbeam technical staff.

## Terminology, Definitions and Notations Used in these Tables

The terminology, definitions and notations used in this brochure are similar to and consistent with those used and listed in AS1684.2:2010 Residential timber framed construction, Part 2:Non-cyclonic areas.

## E-JOIST DESIGN INFORMATION

### Flooring

Specified floor joist spans are independent of flooring type and are therefore suitable for a range of flooring products including: particleboard flooring, plywood flooring or strip flooring.

Floor joist spans are determined in accordance with AS1684.2:2010 Residential timber framed construction, Part 2:Non-cyclonic areas, with a floor self weight of  $40\text{kg/m}^2$  and a floor live load of  $1.5\text{kPa}$  ( $\sim 150\text{kg/m}^2$ ). One third of the floor live load ( $50\text{kg/m}^2$ ) – is considered a permanent live load (PLL).

### e-joist Nomenclature

ej30045 – denotes an e-joist 300mm deep with a 45mm wide flange.

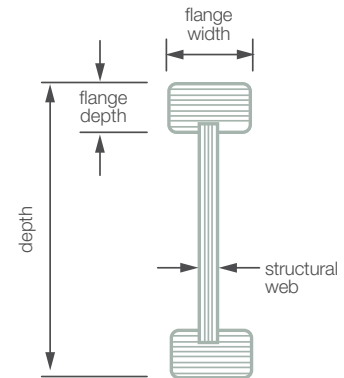

### Heavier Floor Loadings

Heavier permanent floor loads (PLL) – greater than  $40\text{kg/m}^2$  – requires special consideration, e.g. tiled or slate flooring on a mortar bed, spa baths, island benchtops located in the middle  $\frac{1}{3}$  of the joist span, pantries not located over or adjacent to load bearing walls under, or large additional furniture loads in a room. Where such additional floor loadings are to be supported by the floor joists the additional floor loading ( $\text{kg/m}^2$ ) should be determined. The calculated additional floor loading should then be added to the  $40\text{kg/m}^2$  permanent floor loading specified in AS1684. As an example, if the calculated additional permanent floor loading is  $50\text{kg/m}^2$ , the long term permanent floor loading used in the floor design will be  $40\text{kg/m}^2 + 50\text{kg/m}^2 = 90\text{kg/m}^2$ .

### e-house Software

Wesbeam's e-house software can be used to size e-joists for actual member conditions – span, spacing, floor mass, and wind classification.

### Recommended Span Range

The tables are designed to present the building designer with a range of options. Selecting a joist span toward the higher end of the span range will provide the most economic floor system. Selecting a joist span nearer the lower extent of the span range will provide a more rigid floor system.

## FLOOR JOISTS SUPPORTING FLOOR AND CEILING LOADS ONLY

### Recommended Floor Joist Spans (m): Single Spans

| Section Code | Recommended Span Range |    |     |     |     |     |     |    |     |
|--------------|------------------------|----|-----|-----|-----|-----|-----|----|-----|
|              | Single Span            |    |     |     |     |     |     |    |     |
|              | Joist spacings (mm)    |    |     |     |     |     |     |    |     |
|              | 300                    |    | 450 |     | 600 |     |     |    |     |
| ej20045      | 4.3                    | to | 4.5 | 3.2 | to  | 3.8 | 3.0 | to | 3.6 |
| ej24045      | 4.7                    | to | 5.0 | 3.7 | to  | 4.5 | 3.5 | to | 4.2 |
| ej24063      | 5.1                    | to | 5.4 | 4.2 | to  | 4.9 | 3.9 | to | 4.5 |
| ej24090      | 5.7                    | to | 6.1 | 5.0 | to  | 5.4 | 4.6 | to | 5.0 |
| ej30045      | 5.4                    | to | 5.7 | 4.6 | to  | 5.1 | 4.3 | to | 4.7 |
| ej30063      | 5.8                    | to | 6.1 | 5.1 | to  | 5.5 | 4.8 | to | 5.1 |
| ej30090      | 6.5                    | to | 6.9 | 5.8 | to  | 6.2 | 5.3 | to | 5.7 |
| ej36063      | 6.5                    | to | 6.8 | 5.8 | to  | 6.1 | 5.3 | to | 5.7 |
| ej36090      | 7.2                    | to | 7.6 | 6.4 | to  | 6.8 | 5.9 | to | 6.3 |

### Recommended Floor Joist Spans (m): Continuous Spans

Continuous span table values apply to joists that are continuous over three or more supports; if adjacent spans are unequal, the major span is not greater than twice the adjacent minor span.

| Section Code | Recommended Span Range |    |     |     |     |     |     |    |     |
|--------------|------------------------|----|-----|-----|-----|-----|-----|----|-----|
|              | Continuous Span        |    |     |     |     |     |     |    |     |
|              | Joist spacings (mm)    |    |     |     |     |     |     |    |     |
|              | 300                    |    | 450 |     | 600 |     |     |    |     |
| ej20045      | 4.9                    | to | 5.2 | 3.7 | to  | 4.5 | 3.5 | to | 4.2 |
| ej24045      | 5.4                    | to | 5.7 | 4.5 | to  | 5.1 | 4.1 | to | 4.7 |
| ej24063      | 5.8                    | to | 6.2 | 5.0 | to  | 5.5 | 4.6 | to | 5.1 |
| ej24090      | 6.5                    | to | 6.9 | 5.8 | to  | 6.1 | 5.3 | to | 5.6 |
| ej30045      | 6.1                    | to | 6.5 | 5.5 | to  | 5.8 | 5.0 | to | 5.4 |
| ej30063      | 6.6                    | to | 7.0 | 5.8 | to  | 6.2 | 5.4 | to | 5.7 |
| ej30090      | 7.3                    | to | 7.8 | 6.5 | to  | 6.9 | 5.9 | to | 6.4 |
| ej36063      | 7.3                    | to | 7.8 | 6.5 | to  | 6.9 | 6.0 | to | 6.4 |
| ej36090      | 8.1                    | to | 8.6 | 7.2 | to  | 7.7 | 6.6 | to | 7.0 |

Consider as continuous span if Span 1 (major) is not greater than 2 times Span 2. If it is, use the recommended Floor Joist Spans for Single Span above.



- 1 The tables for single and continuous floor joist spans assume a floor self-weight of 40kg/m<sup>2</sup> and a floor live load of 1.5kPa (~150kg/m<sup>2</sup>). One third of the floor live load is considered a permanent live load (PLL).

## E-JOIST CONSTRUCTION INFORMATION

**Diagram D1:**  
e-joint construction information

### Upper Floor Framing

(for clarity, flooring not shown under walls)

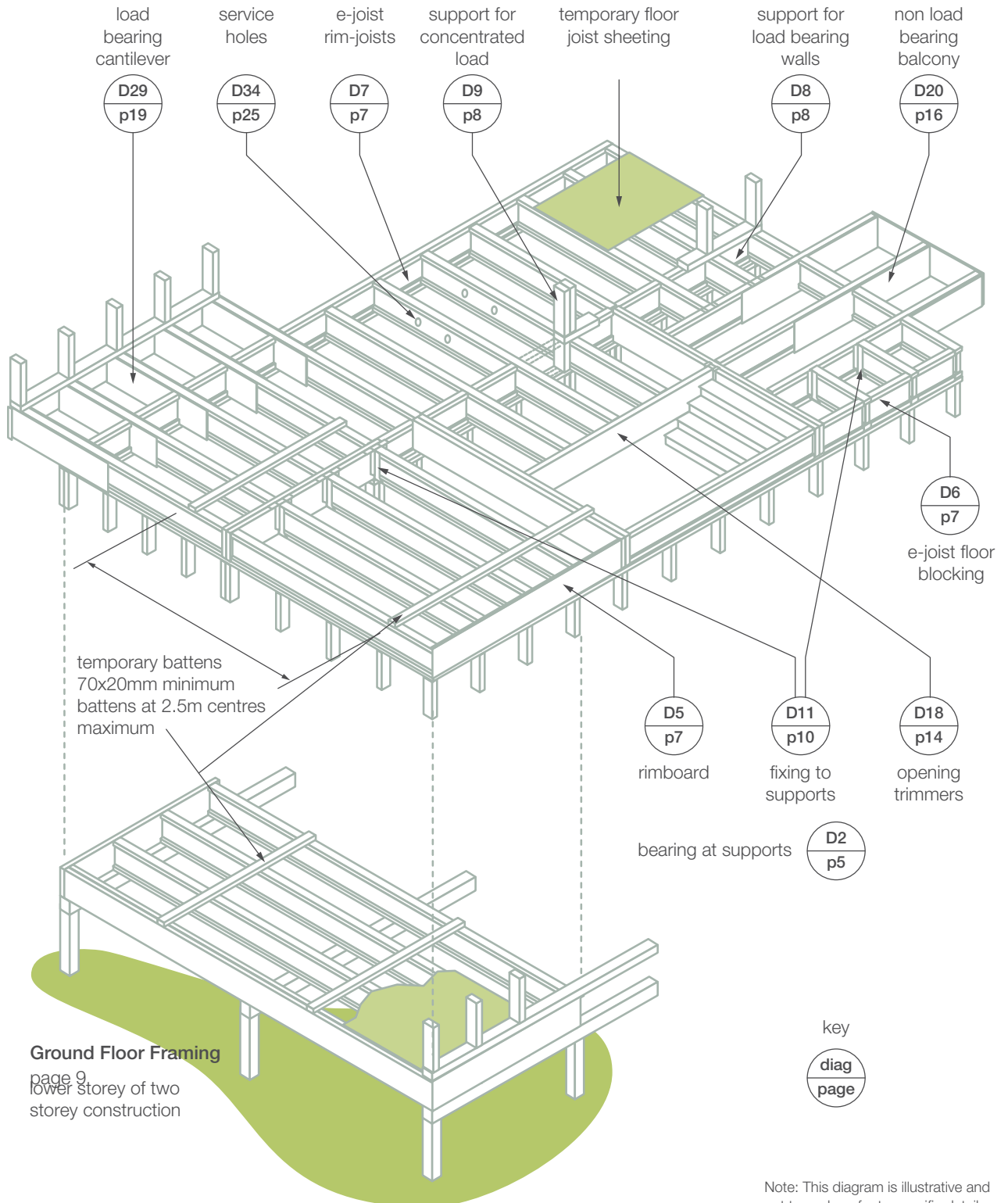

Note: This diagram is illustrative and not to scale, refer to specific details.



## E-JOIST INSTALLATION DETAILS

### Bearing at Supports

**Diagram D2:**  
bearing at supports

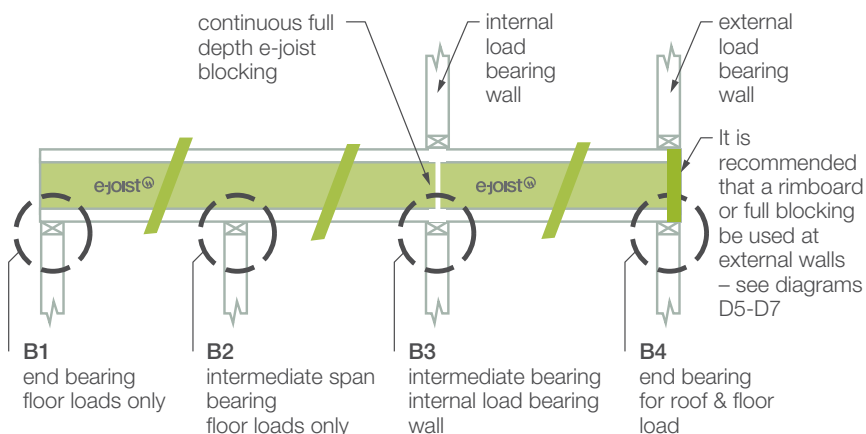

| Detail B1  | End Supports – single or continuous spans                              |                               |               |     |          |  |
|--|--|-------------------------------|---------------|-----|----------|--|
| Minimum Bearing  | 35   |                               |               |     |          |  |
| Detail B2  | Intermediate Supports – continuous spans                               |                               |               |     |          |  |
|  | Joist Type   | Joist Spacing                 |               |     |          |  |
|  |  | 300                           | 450           | 600 |          |  |
| Minimum Bearing  | All e-joists   | 45                            | 45            | 70  |          |  |
| Detail B3  | Intermediate Supports  |                               |               |     |          |  |
| Provide minimum bearing as for intermediate supports (B2) and install continuous full depth e-joint blocking to transfer roof and wall loads to supports |  |                               |               |     |          |  |
| Detail B4  | End Supports with Rimboard or full blocking                            |                               |               |     |          |  |
| Minimum Bearing  | 35   |                               |               |     |          |  |
| Detail B4  | End Supports with no Rimboard or full blocking (just minimum blocking) |                               |               |     |          |  |
|  | Roof Material  | Joist Type                    | Joist Spacing |     |          |  |
|  |  |                               | 300           | 450 | 600      |  |
| Minimum Bearing  | Sheet Roof   | All                           | 45            | 45  | 65 (45s) |  |
|  | Tile Roof  | All 200, 240 and 300 e-joists | 70            | 70  | 90 (65s) |  |
|  |  | ej36063                       | 70            | 70  | 90 (65s) |  |
|  |  | ej36090                       | 70            | 70  | 95 (70s) |  |

1 "(s)" – the value in the brackets is the minimum required bearing length if web stiffeners are installed, refer detail D4.

## E-JOIST INSTALLATION DETAILS

### Support Details

**Diagram D3:**  
nailing at supports

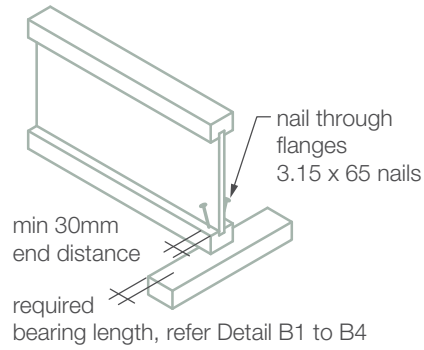

**Diagram D4:**  
web stiffener installation

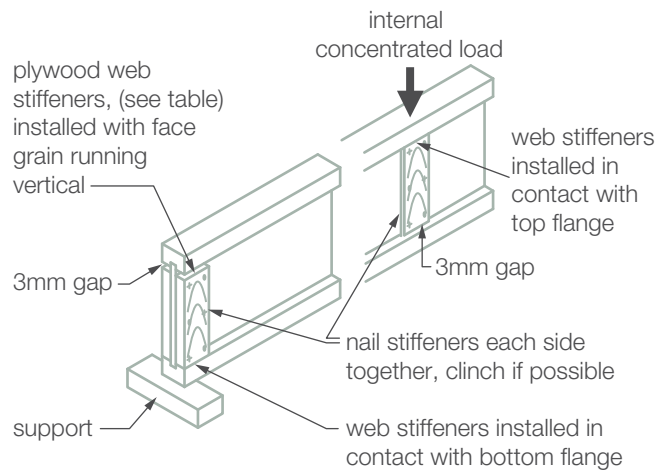

| e-joint Flange Width | Stiffener   | Nail Length |
|----------------------|---|-------------|
| 45mm                 | 17 x 60mm ply                                     | 65mm        |
| 63mm                 | 27 x 60mm ply                                     | 65mm        |
| 90mm                 | 2/19 x 60mm ply<br>39 x 60mm solid timber         | 90mm        |
| e-joint Depth        | Stiffener Nailing Requirements                    |             |
| 200                  | 3 x ø3.15 nails each side clinched where possible |             |
| 240                  |   |             |
| 300                  |   |             |
| 360                  |   |             |

## E-JOIST INSTALLATION DETAILS

### ALL JOISTS TO BE INSTALLED VERTICALLY PLUMB AND KEPT STRAIGHT BETWEEN SUPPORTS.

#### Temporary and Permanent Bracing and Blocking

##### Temporary Blocking

Temporary blocking during construction prevents joists rolling over while the sheet floor is being installed.

##### Minimum Temporary Blocking

Requirements are: the outer three joists (2 spaces) and intermediate joists (2 joist spaces) at no more than 3.6m centres using solid or e-joist floor blocking (see detail D6).

Temporary battens must be also used during construction. Joists must be restrained at a maximum of 2.5m centres with battens (70 x 20mm min) fixed back to points of rigidity (see construction layout diagram D1). Temporary battens must be installed prior to walking on open joists or attempting to lay flooring.

**NOTE** Do not walk on or load floor joists until all blocking, rimboards, temporary bracing, hangers or nailing are installed.

##### Permanent Blocking / Bracing

Permanent Blocking / Bracing provides lateral resistance to transfer the "racking" loads, experienced by the house during wind events, through the floor to the lower bracing system.

If full blocking of exterior walls is undertaken, using one of the following methods shown in diagrams D5-D7, with temporary blocking as described above to all internal walls, then no further lateral bracing calculation is required – this is highly recommended.

##### Fixing of Flooring

Fixings for floors shall be in accordance with AS1684 and manufacturer's recommendations. Nails (and screws) shall be 2.5 times the flooring thickness in length and not less than 2.5mm in diameter. It is recommended that flooring adhesive be used with sheet flooring.

#### Blocking/Bracing: External Load Bearing and Bracing Walls

##### Diagram D5: 17mm rimboard

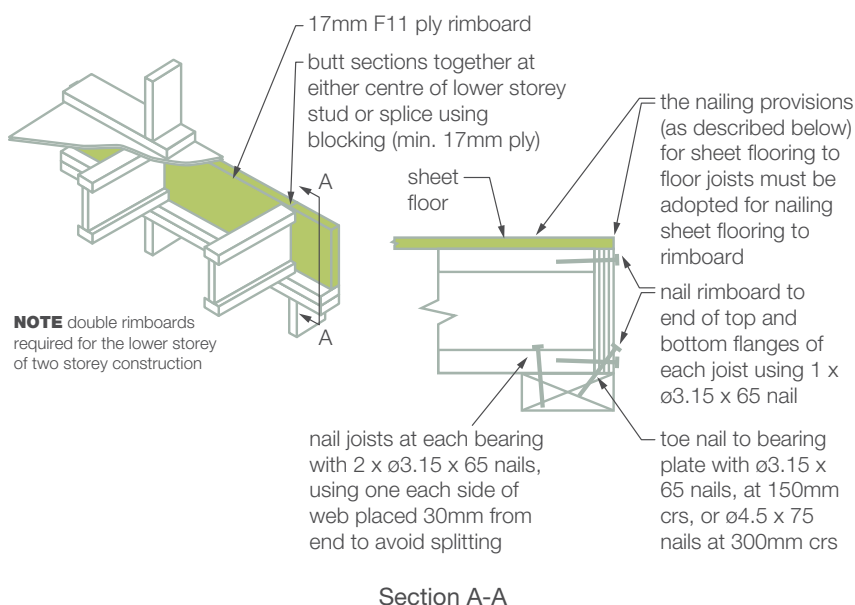

##### Diagram D6: e-joist floor blocking

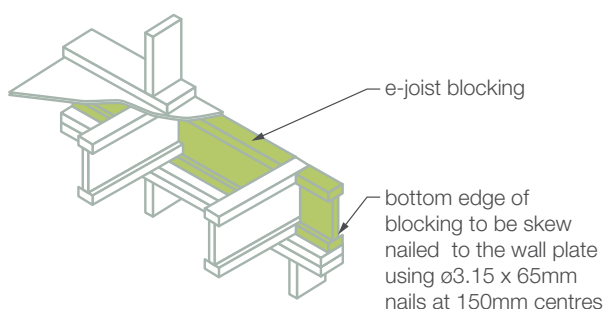

##### Diagram D7: e-joist rim-joist

(only suitable for 45mm flange width e-joists on 90mm plates)

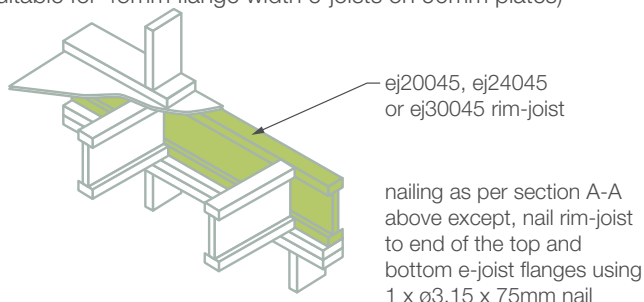

## E-JOIST INSTALLATION DETAILS

### Blocking/Bracing: Internal Load Bearing and Bracing Walls

**Diagram D8:**  
e-joint floor blocking

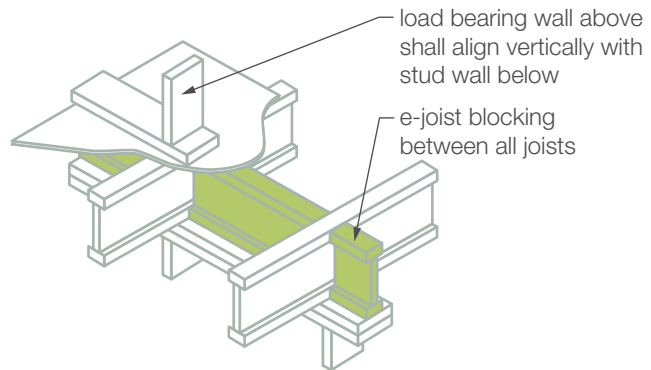

**Diagram D9:**  
support of concentrated loads

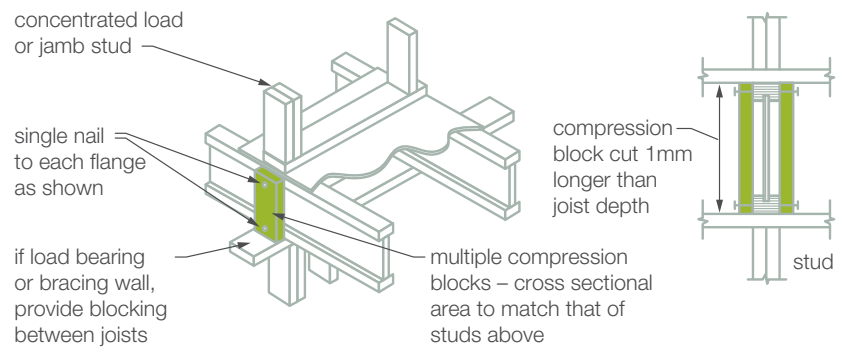



## E-JOIST INSTALLATION DETAILS

### GROUND FLOOR FRAMING

#### Sub-Floor Design

Ground floor joists can be sized using the Floor Joist Supporting Floor and Ceiling Loads Only tables. Sub-floor supports and footings should be designed in accordance with AS1684.2:2010. Solid LVL sub-floor bearers and floor joist supporting parallel load bearing walls shall be designed using the appropriate Wesbeam e-beam. Tables for e-joist and e-beam Floor Joists Supporting Parallel Load Bearing Walls are included in this brochure.

#### Ventilation

The Building Code of Australia stipulates a minimum ventilation requirement. Wall vents shall be built into all sides of the building, with special attention to corners to prevent 'dead spaces'.

**Diagram D10:  
ground floor framing**

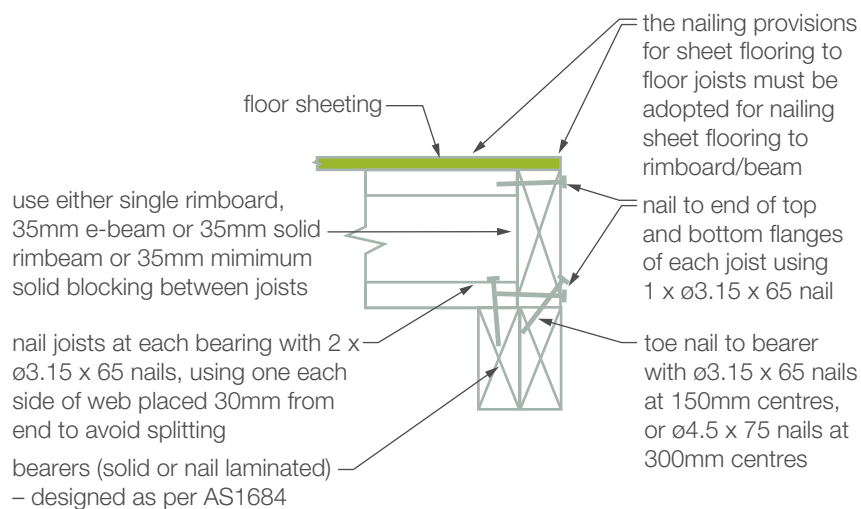
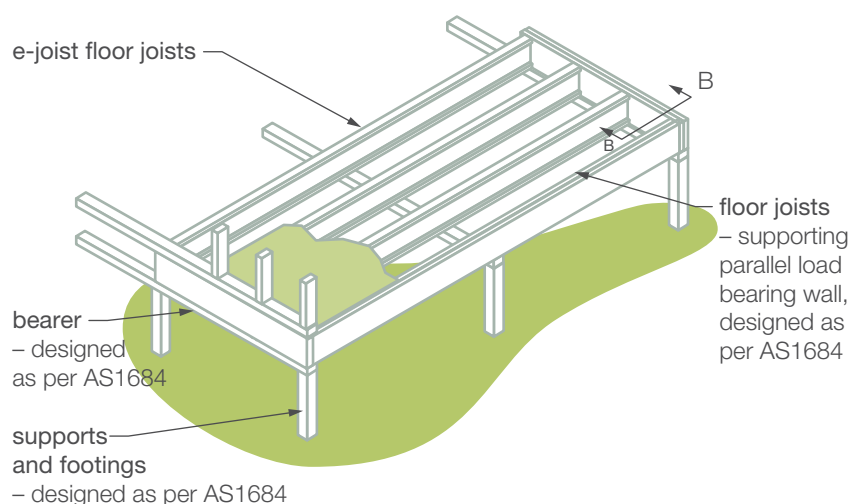

**Section B-B single storey construction**

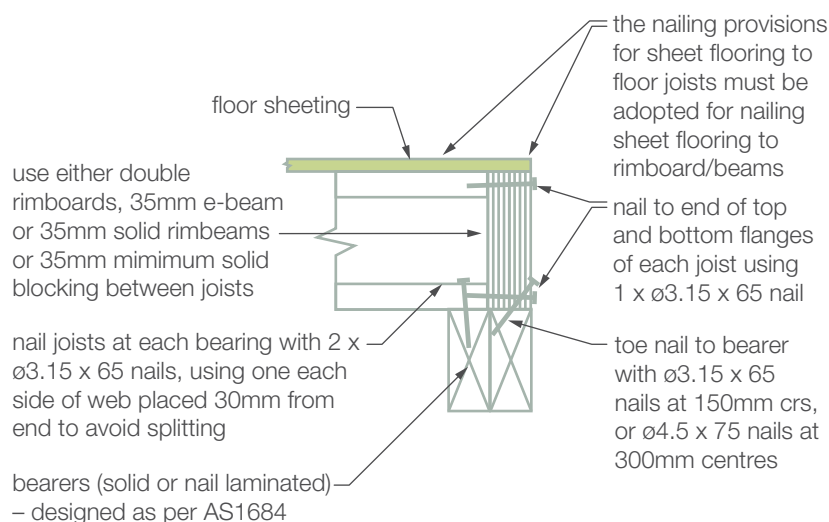

**Section B-B lower storey of two storey construction**

## E-JOIST INSTALLATION DETAILS

### Fixing to Supports

- 1 Refer to MiTek's product literature for hanger installation details – incorrect installation can lead to unsafe or unsatisfactory performance.
- 2 Fix hanger to bearer or wall plate by filling all holes using MiTek  $\phi 3.75 \times 40$ mm reinforced head galvanized nails.
- 3 Fix bottom e-joint flange using 2 x  $\phi 3.75 \times 40$ mm reinforced head nails. Select one dimple each side of the e-joint which will allow the 40mm nail to be driven fully home at a 45° angle.

### Pryda Installation Notes

- 1 Refer to Pryda's product literature for hanger installation details – incorrect installation can lead to unsafe or unsatisfactory performance.
- 2 Fix hanger to bearer or wall plate by filling all holes using  $\phi 3.75 \times 40$ mm galvanized Pryda Timber Connector nails.
- 3 Sit joist in bracket and fix joist tight using a 30 x 6 gauge bugle-head or wafer-head wood screws.

### Diagram D11: joist hanger installation

bearer or wall plate needs to have sufficient thickness to accommodate the nail length specified

partial face mount hangers must support a minimum of 60% of joist depth. web stiffeners are required when top flange is unrestrained (see diagram D4)

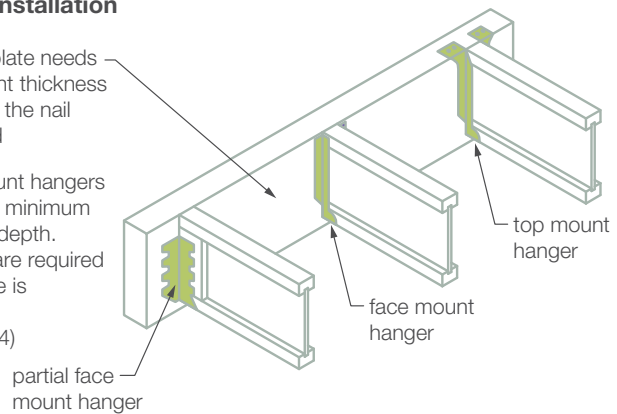

### MiTek I-Joist Hanger Guide

| e-joint | Face Mount Hanger |                      | Top Mount Hanger |                     |
|---------|-------------------|----------------------|------------------|---------------------|
|         | Hanger Code       | Face Nails to Bearer | Hanger Code      | Top Nails to Bearer |
| ej20045 | IBHF20050         | 8                    | IBHT20050        | 6                   |
| ej20063 | IBHF20065         | 8                    | IBHT20065        | 6                   |
| ej20090 | IBHF20090         | 8                    | IBHT20090        | 6                   |
| ej24045 | IBHF24050         | 10                   | IBHT24050        | 6                   |
| ej24063 | IBHF24065         | 10                   | IBHT24065        | 6                   |
| ej24090 | IBHF24090         | 10                   | IBHT24090        | 6                   |
| ej30045 | IBHF30050         | 12                   | IBHT30050        | 6                   |
| ej30063 | IBHF30065         | 12                   | IBHT30065        | 6                   |
| ej30090 | IBHF30090         | 12                   | IBHT30090        | 6                   |
| ej36063 | IBHF36065         | 14                   | IBHT36065        | 6                   |
| ej36090 | IBHF36090         | 14                   | IBHT36090        | 6                   |

### Pryda I-Joist Hanger Guide

| e-joint | Face Mount Hanger |             |                      | Top Mount Hanger |             |                      |
|---------|-------------------|-------------|----------------------|------------------|-------------|----------------------|
|         | Hanger Code       | Fasteners   |                      | Hanger Code      | Fasteners   |                      |
|         |                   | Joist Screw | Face Nails to Bearer |                  | Joist Screw | Face Nails to Bearer |
| ej20045 | LF190/50          | 1           | 8                    | LT200/50         | 1           | 6                    |
| ej20063 | LF200/65          | 1           | 8                    | LT200/65         | 1           | 6                    |
| ej20090 | LF190/90          | 1           | 8                    | LT200/90         | 1           | 6                    |
| ej24045 | LF235/50          | 1           | 10                   | LT240/50         | 1           | 6                    |
| ej24063 | LF235/65          | 1           | 10                   | LT240/65         | 1           | 6                    |
| ej24090 | LF235/90          | 1           | 10                   | LT240/90         | 1           | 6                    |
| ej30045 | LF297/50          | 1           | 12                   | LT300/47         | 1           | 6                    |
| ej30063 | LF290/65          | 1           | 12                   | LT302/65         | 1           | 6                    |
| ej30090 | LF290/90          | 1           | 12                   | LT300/90         | 1           | 6                    |
| ej36063 | LF340/65          | 1           | 14                   | LT360/65         | 1           | 6                    |
| ej36090 | LF350/90          | 1           | 14                   | LT360/90         | 1           | 6                    |

## E-JOIST INSTALLATION DETAILS

### Joist Fixing to Steel Beams or Masonry

For hanger code and fastener requirements refer to Hanger Guide Tables.

**Diagram D12:**  
joist fixing to steel beams or masonry using top mount hangers

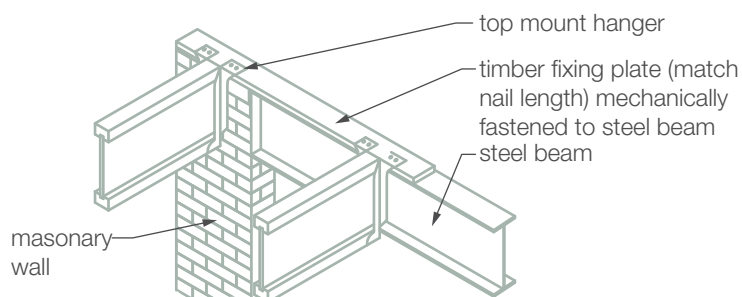

**Diagram D13:**  
joist fixing to steel beams or masonry using face mount hangers

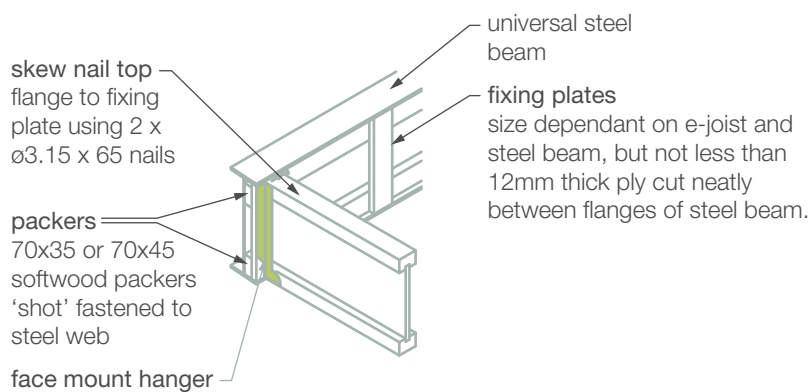

## E-JOIST INSTALLATION DETAILS

### Flange Notching

Bottom and/or top flanges can be notched to a max of 12mm.

DO NOT OVERCUT.

**Diagram D14:  
flange notching**

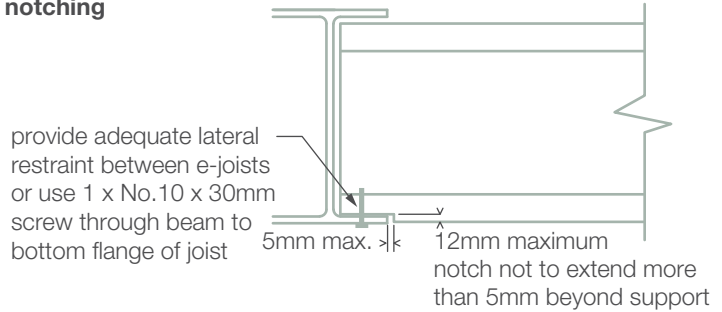

**Diagram D15:  
web cutting**

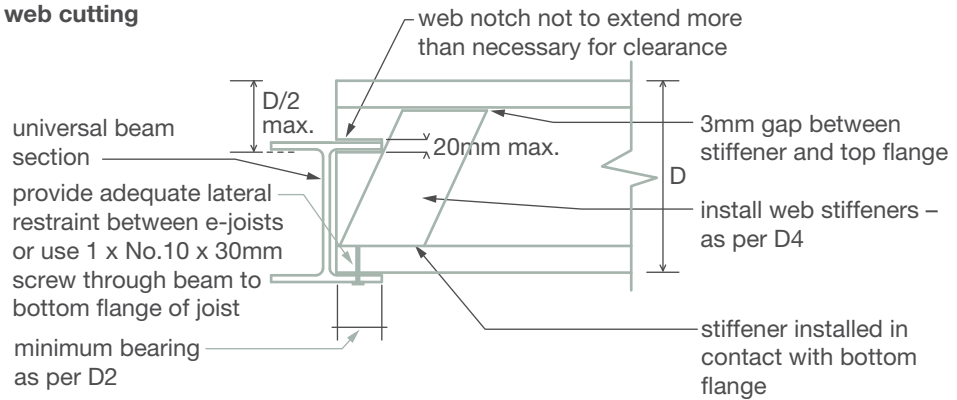

do not overcut

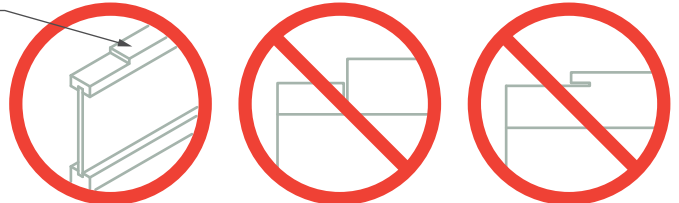

do not chamfer beyond support



**Diagram D16:  
skewed joist support fixing**

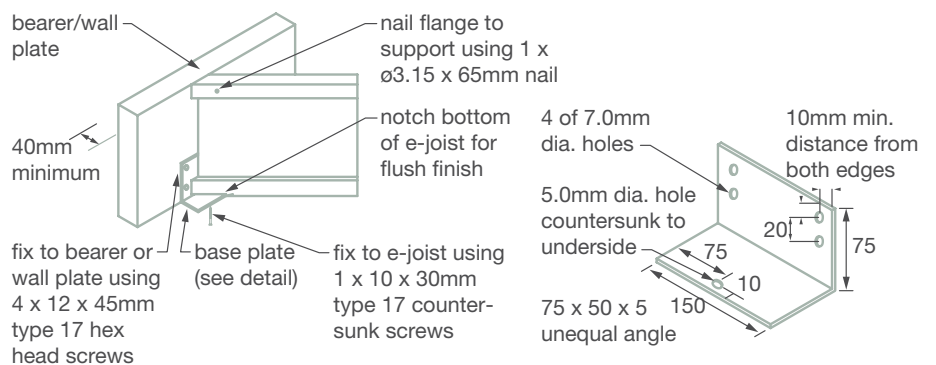

**Note** Propriety skewed angle support brackets are available from MiTek and Pryda.



## E-JOIST INSTALLATION DETAILS

### Bracing and Tie Down

All bracing and tie down to be designed in accordance with AS1684.2:2010 .

### Tie Down

Typical tie down connection details used with solid timber joists (refer AS1684) can also be used with e-joists except that **bolting through flanges is not permitted.**

Refer AS1684.2:2010 Residential timber framed construction Part 2:Non-cyclonic areas Appendix J for further details

**Diagram D17:**  
**tie down to internal brace walls**

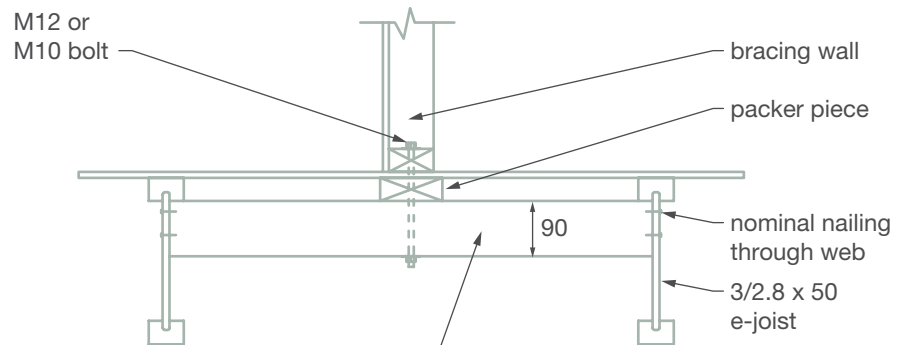

90 x 45mm seasoned timber bridging cleat fixed up against top flange – located at least 200mm min. from end of e-joists. cleats to be placed no closer than 1500mm centres.

## OPENINGS IN FLOORS

### Trimmer

Trimmers provide support to truncated joists (common joists that are truncated to form the opening). They are designed to support typical domestic floor loads and frame one side of an opening.

**Diagram D18:**  
trimmers

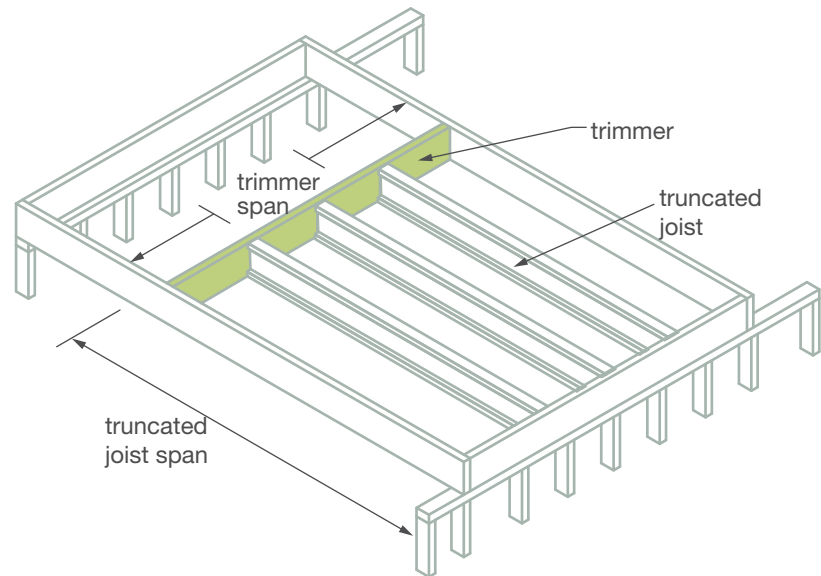

### Trimmers supporting truncated joists

| e-beam<br>Section<br>d x b | Truncated joist span (m) |     |     |     |     |
|----------------------------|--------------------------|-----|-----|-----|-----|
|                            | 1.8                      | 2.4 | 3.6 | 4.8 | 6.0 |
|                            | Maximum Trimmer Span (m) |     |     |     |     |
| 200 x 35                   | 3.4                      | 3.1 | 2.7 | 2.5 | 2.3 |
| 200 x 45                   | 3.7                      | 3.3 | 2.9 | 2.6 | 2.4 |
| 200 x 63                   | 4.1                      | 3.7 | 3.2 | 2.9 | 2.7 |
| 240 x 35                   | 4.1                      | 3.7 | 3.2 | 2.9 | 2.7 |
| 240 x 45                   | 4.3                      | 4.0 | 3.5 | 3.2 | 2.9 |
| 240 x 63                   | 4.7                      | 4.4 | 3.9 | 3.5 | 3.3 |
| 300 x 45                   | 5.1                      | 4.8 | 4.3 | 3.9 | 3.7 |
| 300 x 63                   | 5.6                      | 5.2 | 4.7 | 4.4 | 4.1 |
| 360 x 45                   | 5.9                      | 5.5 | 4.9 | 4.6 | 4.3 |
| 360 x 63                   | 6.4                      | 5.9 | 5.4 | 5.0 | 4.7 |

**Note** The Table assumes permanent floor self-weight of 40kg/m<sup>2</sup>. For higher permanent floor loads use the e-house software package to determine trimmer spans. The floor live load is 1.5kPa (~150kg/m<sup>2</sup>). One third of the floor live load is considered a permanent live load (PLL).

## OPENINGS IN FLOORS

### Trimming Joists

Trimming joists provide support to both the staircase (point load applied from a single stair stringer) as well as the trimmer (point load applied from the truncated joists floor load).

**Diagram D19:**  
trimming joists

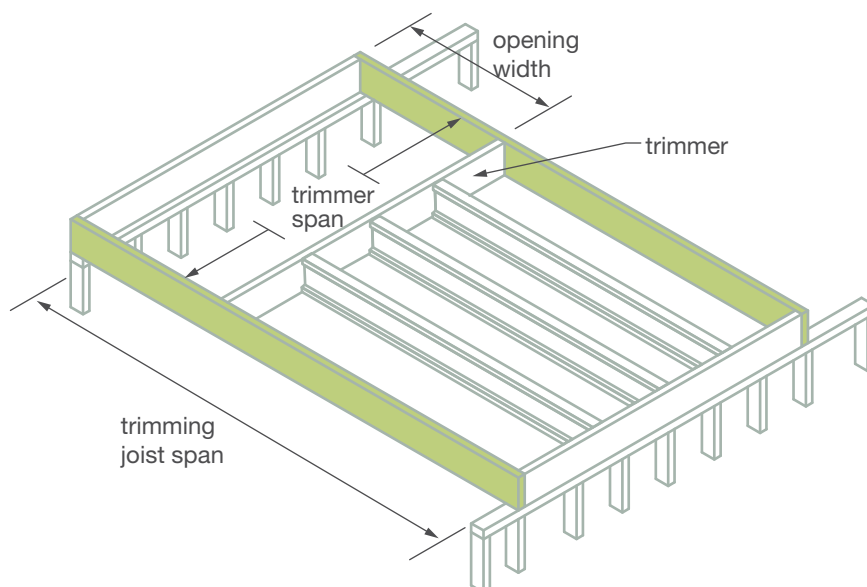

### Trimming Joists supporting trimmers

| e-beam<br>Section<br>d x b | 0.9 metre<br>opening width              |     |     |     | 1.8 metre<br>opening width |     |     |     | 2.7 metre<br>opening width |     |     |     |
|----------------------------|---|-----|-----|-----|----------------------------|-----|-----|-----|----------------------------|-----|-----|-----|
|                            | Trimmer Span (m)                        |     |     |     | Trimmer Span (m)           |     |     |     | Trimmer Span (m)           |     |     |     |
|                            | 2.0                                     | 3.0 | 4.0 | 5.0 | 2.0                        | 3.0 | 4.0 | 5.0 | 2.0                        | 3.0 | 4.0 | 5.0 |
|                            | <b>Maximum Trimming Joist Spans (m)</b> |     |     |     |                            |     |     |     |                            |     |     |     |
| 200 x 35                   | 3.1                                     | 2.9 | 2.7 | 2.5 | 3.0                        | 2.8 | 2.7 | 2.6 | 3.3                        | 3.2 | 3.1 | 3.0 |
| 200 x 45                   | 3.4                                     | 3.1 | 2.9 | 2.7 | 3.2                        | 3.0 | 2.8 | 2.7 | 3.5                        | 3.3 | 3.2 | 3.2 |
| 200 x 63                   | 3.8                                     | 3.5 | 3.3 | 3.1 | 3.6                        | 3.3 | 3.1 | 3.0 | 3.7                        | 3.6 | 3.4 | 3.3 |
| 2/200 x 35                 | 4.0                                     | 3.7 | 3.5 | 3.3 | 3.7                        | 3.4 | 3.2 | 3.1 | 3.9                        | 3.7 | 3.5 | 3.4 |
| 2/200 x 45                 | 4.3                                     | 4.0 | 3.8 | 3.6 | 4.0                        | 3.7 | 3.5 | 3.3 | 4.1                        | 3.9 | 3.7 | 3.6 |
| 240 x 35                   | 3.8                                     | 3.5 | 3.3 | 3.1 | 3.6                        | 3.3 | 3.1 | 3.0 | 3.7                        | 3.6 | 3.4 | 3.3 |
| 240 x 45                   | 4.1                                     | 3.8 | 3.6 | 3.4 | 3.8                        | 3.5 | 3.3 | 3.2 | 4.0                        | 3.8 | 3.6 | 3.5 |
| 240 x 63                   | 4.5                                     | 4.3 | 4.1 | 3.9 | 4.2                        | 3.9 | 3.7 | 3.5 | 4.3                        | 4.1 | 3.9 | 3.7 |
| 2/240 x 35                 | 4.7                                     | 4.4 | 4.2 | 4.1 | 4.4                        | 4.1 | 3.9 | 3.7 | 4.4                        | 4.2 | 4.0 | 3.9 |
| 2/240 x 45                 | 5.0                                     | 4.7 | 4.5 | 4.3 | 4.7                        | 4.4 | 4.1 | 3.9 | 4.6                        | 4.4 | 4.2 | 4.1 |
| 300 x 45                   | 5.0                                     | 4.7 | 4.5 | 4.3 | 4.6                        | 4.3 | 4.1 | 3.9 | 4.6                        | 4.4 | 4.2 | 4.0 |
| 300 x 63                   | 5.4                                     | 5.2 | 5.0 | 4.8 | 5.1                        | 4.7 | 4.5 | 4.3 | 5.0                        | 4.7 | 4.5 | 4.3 |
| 2/300 x 45                 | 6.0                                     | 5.7 | 5.5 | 5.3 | 5.6                        | 5.2 | 5.0 | 4.7 | 5.5                        | 5.1 | 4.9 | 4.7 |
| 360 x 45                   | 5.8                                     | 5.5 | 5.3 | 5.1 | 5.4                        | 5.0 | 4.8 | 4.6 | 5.2                        | 4.9 | 4.7 | 4.5 |
| 360 x 63                   | 6.3                                     | 6.0 | 5.8 | 5.6 | 5.9                        | 5.5 | 5.2 | 5.0 | 5.7                        | 5.4 | 5.1 | 4.9 |
| 2/360 x 45                 | 6.9                                     | 6.6 | 6.4 | 6.2 | 6.5                        | 6.1 | 5.8 | 5.5 | 6.3                        | 5.9 | 5.6 | 5.4 |
| 400 x 75                   | 7.2                                     | 6.9 | 6.7 | 6.4 | 6.7                        | 6.3 | 6.0 | 5.8 | 6.5                        | 6.1 | 5.8 | 5.5 |

- 1 All double members to be nail laminated as per AS1684.
- 2 The Table assumes permanent floor self-weight of 40kg/m<sup>2</sup>. For higher permanent floor loads use the e-house software package to determine trimmer spans. The floor live load is 1.5kPa (~150kg/m<sup>2</sup>). One third of the floor live load is considered a permanent live load (PLL).

## CANTILEVERS FOR BALCONIES (NON-LOAD BEARING)

When installing cantilevered joists to form balconies, attention to detail must be given to ensure that water does not find its way into the structure from water ponding on the surface or wind driven rain. For these reasons, a step down onto the balcony is preferred. This allows the installation of appropriate flashing and a water proofed surface (if desired) to protect joists.

### Backer Block Thickness

| e-joint Flange width | Backer Block |
|----------------------|--------------|
| 45                   | 17mm         |
| 63                   | 27mm         |
| 90                   | 40mm         |

**Diagram D20:**  
cantilevered non-load bearing balcony detail – adjacent joist

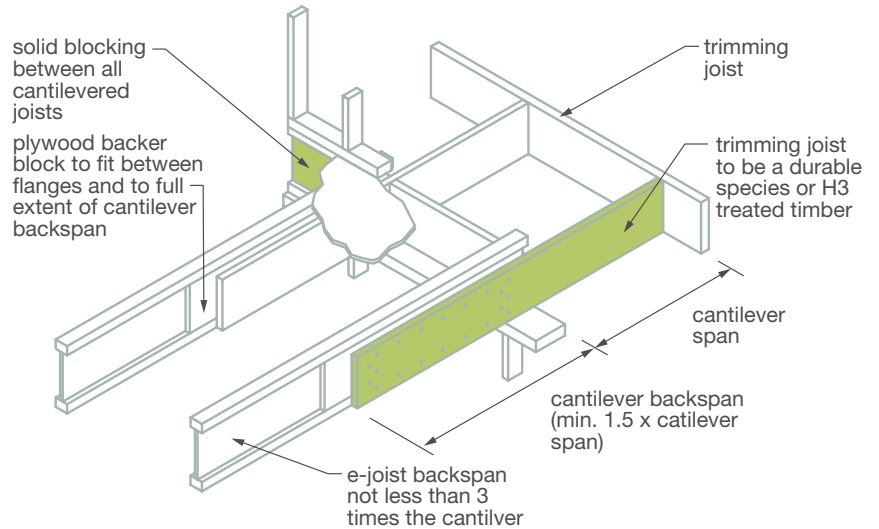

**Diagram D21:**  
cantilevered balcony fixing  
– adjacent joist

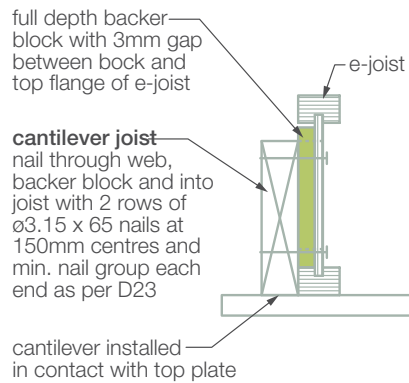

**Diagram D22:**  
cantilevered balcony  
flashing

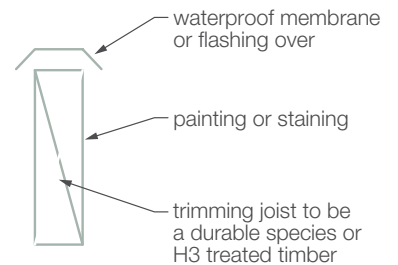

**Diagram D23:**  
cantilevered balcony fixing nested joist – elevation

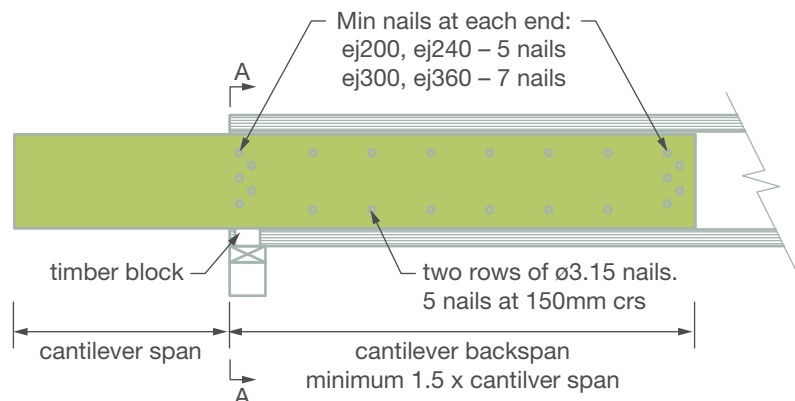



## CANTILEVERS FOR BALCONIES (NON-LOAD BEARING)

**Diagram D24:**  
cantilevered balcony fixing nested joists – sections

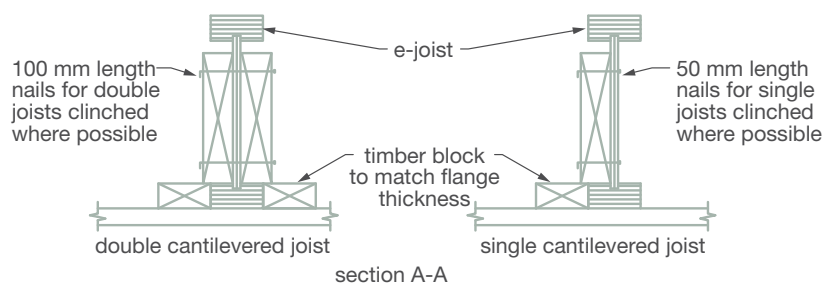

| e-joist Section Code          | e-joist Spacing (mm) | Maximum Balcony Cantilever (m) | Cantilever Joist Options  |                             |
|-------------------------------|----------------------|--------------------------------|---------------------------|-----------------------------|
|                               |                      |                                | Nested Cantilevered Joist | Adjacent Cantilevered Joist |
| ej20045<br>ej20063<br>ej20090 | 450                  | 1.0                            | 2/120 x 35 MGP12          | 140 x 45 MGP12              |
|                               | 450                  | 0.9                            | 2/120 x 35 F7             | 140 x 45 F7                 |
|                               | 600                  | 0.9                            | 2/120 x 35 MGP12          | 140 x 45 MGP12              |
| ej24045                       | 450                  | 1.2                            | 2/140 x 45 MGP12          | 190 x 35 MGP12              |
|                               | 450                  | 1.1                            | 2/140 x 45 F7             | 190 x 45 F7                 |
|                               | 600                  | 1.0                            | 2/140 x 45 F7             | 190 x 45 F7                 |
| ej24063                       | 450                  | 1.2                            | 2/140 x 45 F7             | 190 x 45 F7                 |
|                               | 600                  | 1.1                            | 2/140 x 35 MGP12          | 190 x 45 F7                 |
| ej24090                       | 450                  | 1.3                            | 2/140 x 35 MGP12          | Not recommended             |
|                               | 600                  | 1.2                            | 2/140 x 35 MGP12          |                             |
| ej30045                       | 450                  | 1.4                            | 2/190 x 35 F7             | 240 x 35 F7                 |
|                               | 600                  | 1.3                            | 2/190 x 45 F7             | 240 x 45 F7                 |
| ej30063                       | 450                  | 1.5                            | 2/190 x 45 F7             | 240 x 45 F7                 |
|                               | 600                  | 1.3                            | 2/190 x 35 F7             | 240 x 35 F7                 |
| ej30090                       | 450                  | 1.6                            | 2/190 x 45 F7             | Not recommended             |
|                               | 600                  | 1.5                            | 2/190 x 45 F7             |                             |
| ej36063                       | 450                  | 1.7                            | 2/240 x 35 F7             | 290 x 45 F7                 |
|                               | 600                  | 1.6                            | 240 x 45 F7               | 290 x 45 F7                 |
| ej36090                       | 450                  | 1.8                            | 240 x 35 F7               | Not recommended             |
|                               | 600                  | 1.7                            | 2/240 x 45 F7             |                             |

**Note** The Table assumes permanent floor self-weight of 40kg/m<sup>2</sup>. For higher permanent floor loads use the e-house software package to determine cantilever spans. The floor live load is 1.5kPa (~150kg/m<sup>2</sup>). One third of the floor live load is considered a permanent live load (PLL).

## DETERMINATION OF ROOF LOAD WIDTH (RLW)

Roof Load Width (RLW) is used as an indicator of the roof loads carried by loadbearing wall members and their supporting sub-structure. The following diagrams illustrate the RLWs for typical roof construction.

**Note** The RLW also includes the overhang length.

### Trussed Roof

### Conventional / Pitched Roof

**Diagram D25:**  
trussed roof

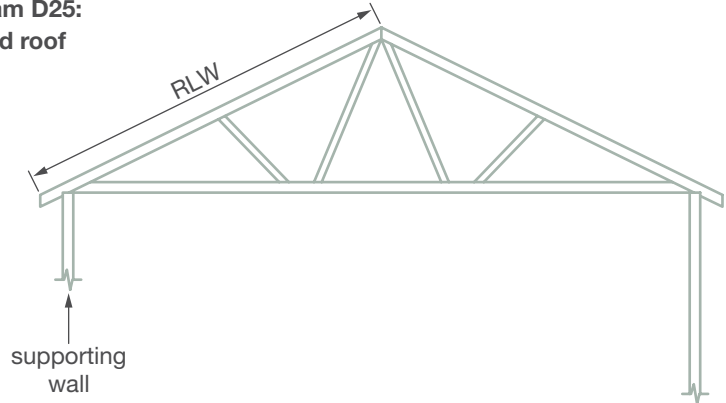

**Diagram D26:**  
cathedral

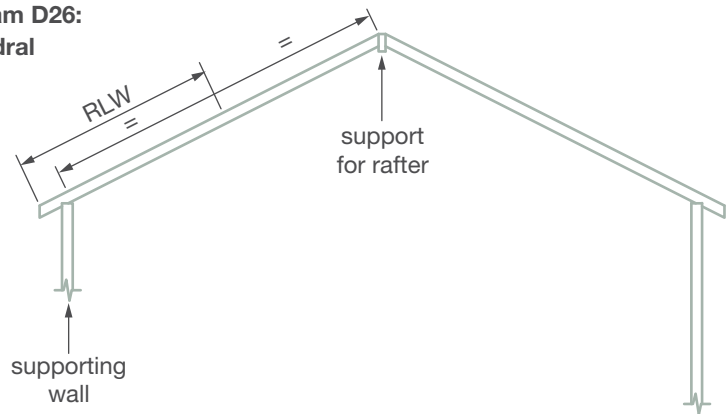

**Diagram D27:**  
coupled roofs with underpurlins – no ridge struts

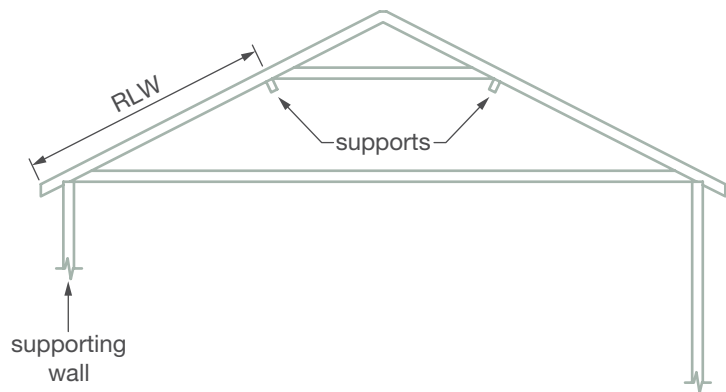

**Diagram D28:**  
coupled roofs with underpurlins and ridge struts

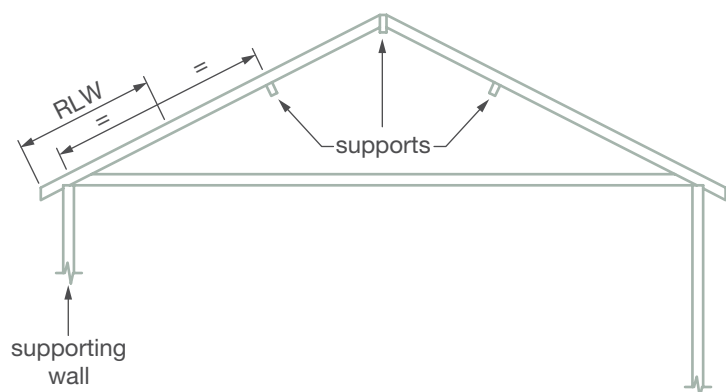

## LOAD BEARING CANTILEVERS

(Supporting Roof, Wall and Floor Loads)

In some instances, e-joists may cantilever to support an external loadbearing wall. It may be necessary to “reinforce” the cantilever to support the applied load. The tables on the following pages indicate the maximum allowable cantilever based on the applied roof mass, RLW and joist spacing. The required reinforcement must be installed to support the loading.

**Diagram D29:**  
load bearing cantilever detail

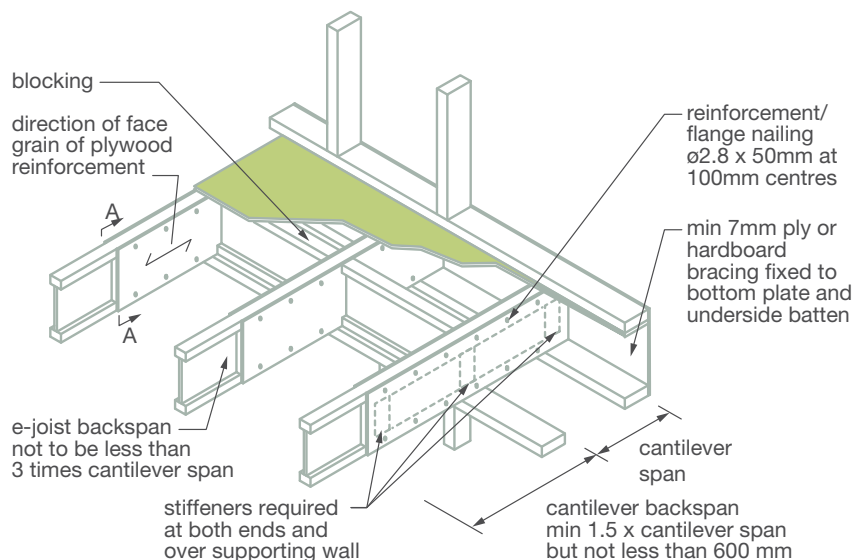

### Required Reinforcement:

- R0** Reinforcement not required
- R1** Full depth 15mm F11 structural plywood nailed to one side of each joist. Fix plywood to flange with  $\phi 2.8 \times 50\text{mm}$  galv. nails at 100mm centres.
- R2** Full depth 15mm F11 structural plywood nailed to both sides of each joist. Fix plywood to flange with  $\phi 2.8 \times 50\text{mm}$  galv. nails at 100mm centres.

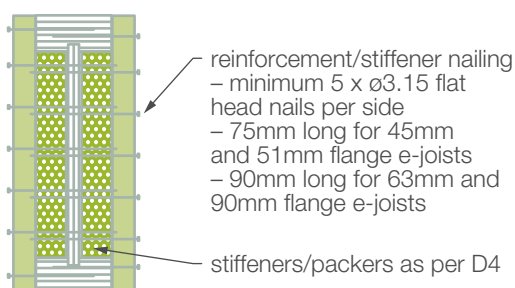
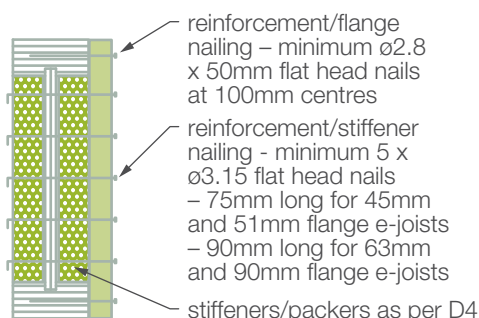

section A-A



**LOAD BEARING CANTILEVERS SUPPORTING TILE ROOF**

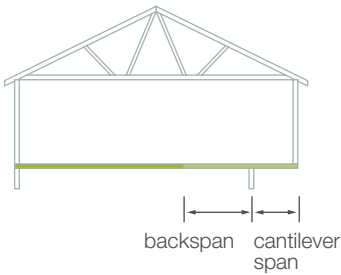

- R0** Reinforcement not required.
- R1** Reinforcement on one side with 15mm F11 structural plywood with face grain running horizontally, nail fixed as specified.
- R2** Reinforcement on both sides with 15mm F11 structural plywood with face grain running horizontally, nail fixed as specified.
- NS** Signifies the joist size is not suitable for the cantilever span and load.

- 1 Tabulated figures assume a uniform roof load width. Joist supporting concentrated loads from window openings and the like will require special engineering consideration.
- 2 Installation requires insertion of stiffeners between the 15mm reinforcing plywood and the web at both ends and the supporting point.
- 3 Ply reinforcement to be nailed to stiffeners and web and clinched if singly reinforced or penetrating the stiffener on the other side if doubly reinforced. A minimum of 5 nails per side.
- 4 Reinforcement plywood to extend along the backspan at least 1.5 x cantilever span but not less than 600mm.
- 5 e-joint backspan to be not less than 3 times the cantilever span.

| Maximum Cantilever Span (mm)     | e-joint Section Code | Roof Load Width (m) |     |     |     |     |     |     |     |     |
|----------------------------------|----------------------|---------------------|-----|-----|-----|-----|-----|-----|-----|-----|
|                                  |                      | 4.0                 |     |     | 6.0 |     |     | 8.0 |     |     |
|                                  |                      | Joist Spacing (mm)  |     |     |     |     |     |     |     |     |
|                                  |                      | 300                 | 450 | 600 | 300 | 450 | 600 | 300 | 450 | 600 |
| <b>Reinforcement requirement</b> |                      |                     |     |     |     |     |     |     |     |     |
| 300                              | ej20045              | R0                  | R0  | R0  | R0  | R1  | R1  | R1  | R1  | R2  |
|                                  | ej20063              | R0                  | R0  | R0  | R0  | R1  | R1  | R1  | R1  | R2  |
|                                  | ej20090              | R0                  | R0  | R0  | R0  | R1  | R1  | R1  | R1  | R2  |
|                                  | ej24045              | R0                  | R0  | R0  | R0  | R0  | R1  | R0  | R1  | R1  |
|                                  | ej24063              | R0                  | R0  | R0  | R0  | R0  | R1  | R0  | R1  | R1  |
|                                  | ej24090              | R0                  | R0  | R0  | R0  | R0  | R1  | R0  | R1  | R1  |
|                                  | ej30045              | R0                  | R0  | R0  | R0  | R0  | R0  | R0  | R0  | R1  |
|                                  | ej30063              | R0                  | R0  | R0  | R0  | R0  | R0  | R0  | R0  | R1  |
|                                  | ej30090              | R0                  | R0  | R0  | R0  | R0  | R0  | R0  | R0  | R1  |
|                                  | ej36063              | R0                  | R0  | R0  | R0  | R0  | R0  | R0  | R0  | R0  |
| ej36090                          | R0                   | R0                  | R0  | R0  | R0  | R0  | R0  | R0  | R0  |     |
| 600                              | ej20045              | R0                  | R1  | NS  | R1  | NS  | NS  | NS  | NS  | NS  |
|                                  | ej20063              | R0                  | R1  | NS  | R1  | NS  | NS  | NS  | NS  | NS  |
|                                  | ej20090              | R0                  | R1  | NS  | R1  | NS  | NS  | NS  | NS  | NS  |
|                                  | ej24045              | R0                  | NS  | NS  | R0  | R1  | NS  | R1  | NS  | NS  |
|                                  | ej24063              | R0                  | R0  | R0  | R0  | R0  | R1  | R0  | R2  | NS  |
|                                  | ej24090              | R0                  | R0  | R0  | R0  | R0  | R1  | R0  | R1  | R2  |
|                                  | ej30045              | R0                  | R0  | R0  | R0  | R0  | R0  | R0  | R0  | R0  |
|                                  | ej30063              | R0                  | R0  | R0  | R0  | R0  | R0  | R0  | R0  | R0  |
|                                  | ej30090              | R0                  | R0  | R0  | R0  | R0  | R0  | R0  | R0  | R0  |
|                                  | ej36063              | R0                  | R0  | R0  | R0  | R0  | R0  | R0  | R0  | R0  |
| ej36090                          | R0                   | R0                  | R0  | R0  | R0  | R0  | R0  | R0  | R0  |     |
| 900                              | ej20045              | NS                  | NS  | NS  | NS  | NS  | NS  | NS  | NS  | NS  |
|                                  | ej20063              | NS                  | NS  | NS  | NS  | NS  | NS  | NS  | NS  | NS  |
|                                  | ej20090              | NS                  | NS  | NS  | NS  | NS  | NS  | NS  | NS  | NS  |
|                                  | ej24045              | R0                  | NS  | NS  | NS  | NS  | NS  | NS  | NS  | NS  |
|                                  | ej24063              | R0                  | R1  | NS  | R1  | NS  | NS  | NS  | NS  | NS  |
|                                  | ej24090              | R0                  | R0  | R2  | R0  | R1  | NS  | R1  | NS  | NS  |
|                                  | ej30045              | R1                  | NS  | NS  | NS  | NS  | NS  | NS  | NS  | NS  |
|                                  | ej30063              | R0                  | NS  | NS  | NS  | NS  | NS  | NS  | NS  | NS  |
|                                  | ej30090              | R0                  | R0  | R2  | R0  | NS  | NS  | R2  | NS  | NS  |
|                                  | ej36063              | R0                  | R0  | R2  | R0  | NS  | NS  | R2  | R0  | R0  |
| ej36090                          | R0                   | R0                  | R0  | R0  | R1  | NS  | R0  | NS  | NS  |     |
| 1200                             | ej20045              | NS                  | NS  | NS  | NS  | NS  | NS  | NS  | NS  | NS  |
|                                  | ej20063              | NS                  | NS  | NS  | NS  | NS  | NS  | NS  | NS  | NS  |
|                                  | ej20090              | NS                  | NS  | NS  | NS  | NS  | NS  | NS  | NS  | NS  |
|                                  | ej24045              | NS                  | NS  | NS  | NS  | NS  | NS  | NS  | NS  | NS  |
|                                  | ej24063              | NS                  | NS  | NS  | NS  | NS  | NS  | NS  | NS  | NS  |
|                                  | ej24090              | R0                  | NS  | NS  | NS  | NS  | NS  | NS  | NS  | NS  |
|                                  | ej30045              | R0                  | NS  | NS  | NS  | NS  | NS  | NS  | NS  | NS  |
|                                  | ej30063              | R0                  | NS  | NS  | NS  | NS  | NS  | NS  | NS  | NS  |
|                                  | ej30090              | R0                  | R0  | R2  | R0  | NS  | NS  | R2  | NS  | NS  |
|                                  | ej36063              | R0                  | R0  | R2  | R0  | NS  | NS  | R2  | NS  | NS  |
| ej36090                          | R0                   | R0                  | R0  | R0  | R1  | NS  | R0  | NS  | NS  |     |

## FLOOR JOISTS SUPPORTING PARALLEL LOAD BEARING WALLS

### Continuously Supported

Continuously supported e-joists are capable of transferring uniformly distributed loads arising from parallel loadbearing walls through to the supporting structure below.

Care must be taken to adequately support the web of the joists from concentrated point loads (as per D4).

**Diagram D30:**  
continuously supported

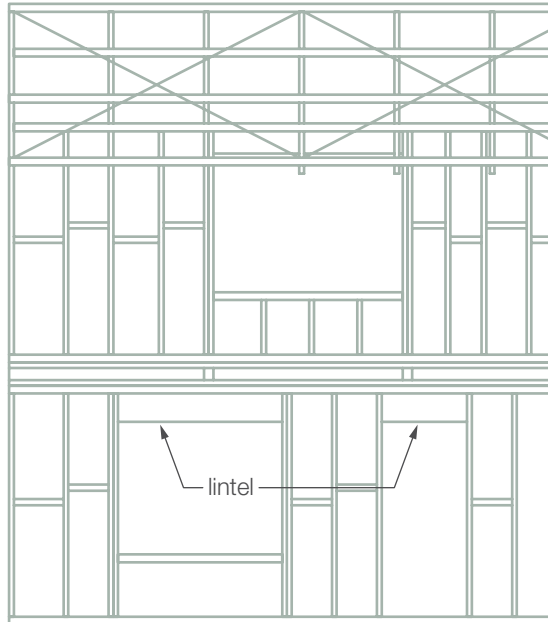

**Diagram D31:**  
platform floor

single e-beam may be used (alternative support for a ceiling may be needed)

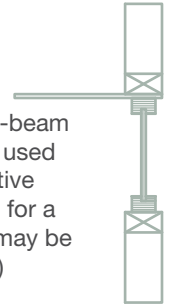

**Diagram D32:**  
fitted floor

double e-joists required for fixing of flooring (and ceiling)

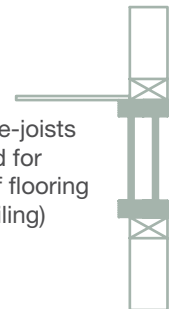

### Over Openings

e-joists spanning over openings supporting parallel loadbearing walls shall be designed in accordance with the span tables - e-joist Floor Joists Supporting Parallel Load Bearing Walls.

For larger openings an e-beam may be required, and shall be designed in accordance with the span tables - e-beam Floor Joists Supporting Parallel Load Bearing Walls.

**Diagram D33:**  
over openings

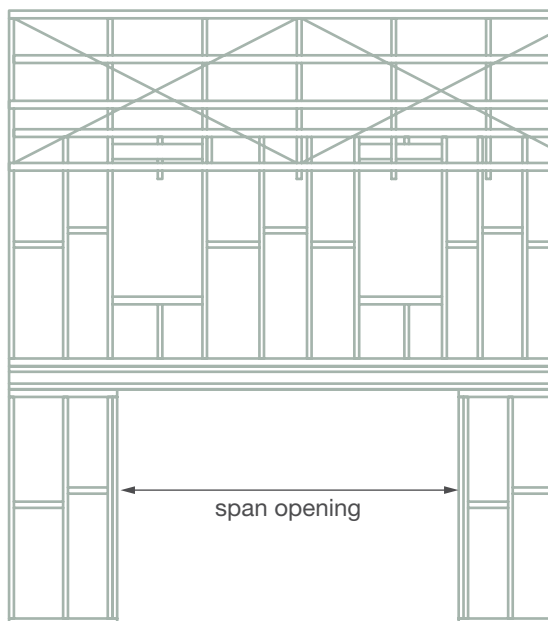



## E-JOIST FLOOR JOISTS SUPPORTING PARALLEL LOAD BEARING WALLS

### e-joint spanning over openings

| e-joint   | Wall Supporting Sheet Roof       |                   |                   |                   |                   |                   |                                      |                    |                    |                    |                    |                    |
|-----------|----------------------------------|-------------------|-------------------|-------------------|-------------------|-------------------|--------------------------------------|--------------------|--------------------|--------------------|--------------------|--------------------|
|           | Maximum Single Span <sup>1</sup> |                   |                   |                   |                   |                   | Maximum Continuous Span <sup>2</sup> |                    |                    |                    |                    |                    |
|           | Roof Load Width (m)              |                   |                   |                   |                   |                   |                                      |                    |                    |                    |                    |                    |
|           | 1.8                              | 2.4               | 3.6               | 4.8               | 6.0               | 7.2               | 1.8                                  | 2.4                | 3.6                | 4.8                | 6.0                | 7.2                |
|           | Span Opening (m) – see D33       |                   |                   |                   |                   |                   |                                      |                    |                    |                    |                    |                    |
| ej20045   | 2.7                              | 2.6               | 2.3               | 2.0               | 1.7               | 1.5               | 2.9                                  | 2.5                | 2.0                | 1.6                | 1.3                | 1.2                |
| 2/ej20045 | 3.6                              | 3.4               | 3.1               | 2.8               | 2.6               | 2.5               | 4.6                                  | 4.4                | 3.9                | 3.2                | 2.7                | 2.3                |
| ej20063   | 3.0                              | 2.9               | 2.5               | 2.1               | 1.7               | 1.5               | 2.9                                  | 2.5                | 2.0                | 1.6                | 1.3                | 1.2                |
| ej24045   | 3.2                              | 3.0               | 2.7               | 2.5               | 2.2               | 1.9               | 3.9                                  | 3.3                | 2.6                | 2.1                | 1.8                | 1.5                |
| 2/ej24045 | 4.1                              | 3.9               | 3.5               | 3.3               | 3.1               | 2.9               | 5.1                                  | 4.9                | 4.5                | 4.2                | 3.5                | 3.1                |
| ej24063   | 3.5                              | 3.3               | 2.9               | 2.6               | 2.2               | 1.9               | 3.9                                  | 3.3                | 2.6                | 2.1                | 1.8                | 1.5                |
| ej30045   | 3.8                              | 3.5               | 3.2               | 2.9               | 2.7 <sub>45</sub> | 2.5 <sub>45</sub> | 4.7                                  | 4.4                | 3.4                | 2.8                | 2.4                | 2.0                |
| 2/ej30045 | 4.8                              | 4.6               | 4.2               | 3.9               | 3.6               | 3.4               | 5.1                                  | 4.8                | 4.4                | 4.2                | 4.0                | 3.7                |
| ej30063   | 4.1                              | 3.9               | 3.5               | 3.2 <sub>45</sub> | 2.9 <sub>45</sub> | 2.5 <sub>45</sub> | 5.0                                  | 4.4                | 3.4                | 2.8                | 2.3                | 2.0                |
| ej36063   | 4.7                              | 4.5 <sub>45</sub> | 4.0 <sub>45</sub> | 3.7 <sub>65</sub> | 3.4 <sub>65</sub> | 3.0 <sub>65</sub> | 5.5 <sub>110</sub>                   | 5.1 <sub>130</sub> | 3.9 <sub>130</sub> | 3.2 <sub>130</sub> | 2.7 <sub>130</sub> | 2.4 <sub>130</sub> |

| e-joint   | Wall Supporting Tile Roof        |                   |                   |                   |                   |                   |                                      |                    |                    |                    |                    |                    |
|-----------|----------------------------------|-------------------|-------------------|-------------------|-------------------|-------------------|--------------------------------------|--------------------|--------------------|--------------------|--------------------|--------------------|
|           | Maximum Single Span <sup>1</sup> |                   |                   |                   |                   |                   | Maximum Continuous Span <sup>2</sup> |                    |                    |                    |                    |                    |
|           | Roof Load Width (m)              |                   |                   |                   |                   |                   |                                      |                    |                    |                    |                    |                    |
|           | 1.8                              | 2.4               | 3.6               | 4.8               | 6.0               | 7.2               | 1.8                                  | 2.4                | 3.6                | 4.8                | 6.0                | 7.2                |
|           | Span Opening (m) – see D33       |                   |                   |                   |                   |                   |                                      |                    |                    |                    |                    |                    |
| ej20045   | 2.2                              | 1.8               | 1.3               | NS                | NS                | NS                | 1.8                                  | 1.5                | NS                 | NS                 | NS                 | NS                 |
| 2/ej20045 | 3.0                              | 2.7               | 2.4               | 2.1               | 1.7               | 1.4               | 3.6                                  | 2.9                | 2.1                | 1.7                | 1.4                | 1.2                |
| ej20063   | 2.3                              | 1.8               | 1.3               | NS                | NS                | NS                | 1.8                                  | 1.5                | NS                 | NS                 | NS                 | NS                 |
| ej24045   | 2.6                              | 2.4               | 1.7               | 1.4               | NS                | NS                | 2.4                                  | 1.9                | 1.4                | NS                 | NS                 | NS                 |
| 2/ej24045 | 3.4                              | 3.1               | 2.8               | 2.5               | 2.2               | 1.9               | 4.4                                  | 3.8                | 2.8                | 2.2                | 1.8                | 1.5                |
| ej24063   | 2.8                              | 2.4               | 1.7               | 1.4               | NS                | NS                | 2.4                                  | 1.9                | 1.4                | NS                 | NS                 | NS                 |
| ej30045   | 3.1                              | 2.8 <sub>45</sub> | 2.3 <sub>45</sub> | 1.8 <sub>45</sub> | 1.5 <sub>45</sub> | 1.3 <sub>45</sub> | 3.1                                  | 2.5                | 1.9                | 1.5                | 1.2                | NS                 |
| 2/ej30045 | 4.1                              | 3.7               | 3.3               | 3.0               | 2.7 <sub>45</sub> | 2.5 <sub>45</sub> | 4.3                                  | 4.1                | 3.6                | 2.9                | 2.4                | 2.0                |
| ej30063   | 3.4 <sub>45</sub>                | 3.1 <sub>45</sub> | 2.3 <sub>45</sub> | 1.8 <sub>45</sub> | 1.5 <sub>45</sub> | 1.3 <sub>45</sub> | 3.1                                  | 2.5                | 1.8                | 1.5                | 1.2                | NS                 |
| ej36063   | 3.9 <sub>65</sub>                | 3.6 <sub>65</sub> | 2.7 <sub>65</sub> | 2.1 <sub>65</sub> | 1.7 <sub>65</sub> | 1.5 <sub>65</sub> | 3.6 <sub>130</sub>                   | 3.0 <sub>130</sub> | 2.2 <sub>130</sub> | 1.7 <sub>130</sub> | 1.4 <sub>130</sub> | 1.2 <sub>130</sub> |

- 1** For single span, end bearing not less than 35mm unless noted otherwise by a subscript. Subscript value 45 and 65 indicates bearing length, except if stiffeners are installed, bearing lengths may be reduced to 35mm and 45mm respectively.
- 2** For continuous span, end bearing shall not be less than 35mm. Bearing at intermediate supports shall not be less than 90mm unless indicated otherwise by a subscript. Where a subscript value indicates bearing at an intermediate support needs to be more than 90mm, an alternative is to install with 90mm bearing and web stiffeners at that support.
- 3** NS – Not Suitable.

## E-BEAM FLOOR JOISTS SUPPORTING PARALLEL LOAD BEARING WALLS

### e-beam spanning over openings

| e-beam     | Wall Supporting Sheet Roof       |     |     |     |     |     |                                      |     |     |                   |                    |                    |
|------------|----------------------------------|-----|-----|-----|-----|-----|--------------------------------------|-----|-----|-------------------|--------------------|--------------------|
|            | Maximum Single Span <sup>1</sup> |     |     |     |     |     | Maximum Continuous Span <sup>2</sup> |     |     |                   |                    |                    |
|            | Roof Load Width (m)              |     |     |     |     |     |                                      |     |     |                   |                    |                    |
|            | 1.8                              | 2.4 | 3.6 | 4.8 | 6.0 | 7.2 | 1.8                                  | 2.4 | 3.6 | 4.8               | 6.0                | 7.2                |
|            | Span Opening (m) – see D33       |     |     |     |     |     |                                      |     |     |                   |                    |                    |
| 200 x 45   | 3.3                              | 3.1 | 2.9 | 2.7 | 2.5 | 2.4 | 4.4                                  | 4.2 | 3.8 | 3.6               | 3.4                | 3.2                |
| 200 x 63   | 3.6                              | 3.5 | 3.2 | 3.0 | 2.8 | 2.7 | 4.8                                  | 4.6 | 4.3 | 4.0               | 3.8                | 3.6                |
| 2/200 x 45 | 4.1                              | 3.9 | 3.6 | 3.3 | 3.2 | 3.0 | 5.2                                  | 5.0 | 4.7 | 4.5               | 4.2                | 4.1                |
| 2/200 x 63 | 4.5                              | 4.3 | 4.0 | 3.7 | 3.5 | 3.4 | 5.6                                  | 5.4 | 5.1 | 4.9               | 4.7                | 4.5                |
| 240 x 45   | 3.9                              | 3.7 | 3.4 | 3.2 | 3.0 | 2.9 | 5.0                                  | 4.9 | 4.6 | 4.3               | 4.1                | 3.9 <sub>75</sub>  |
| 240 x 63   | 4.3                              | 4.1 | 3.8 | 3.6 | 3.4 | 3.2 | 5.5                                  | 5.3 | 5.0 | 4.7               | 4.5                | 4.3                |
| 2/240 x 45 | 4.8                              | 4.6 | 4.3 | 4.0 | 3.8 | 3.6 | 5.9                                  | 5.7 | 5.4 | 5.1               | 4.9                | 4.8                |
| 2/240 x 63 | 5.1                              | 5.0 | 4.7 | 4.4 | 4.2 | 4.0 | 6.4                                  | 6.2 | 5.8 | 5.6               | 5.3                | 5.2                |
| 300 x 45   | 4.8                              | 4.6 | 4.3 | 4.0 | 3.8 | 3.6 | 6.0                                  | 5.7 | 5.4 | 5.1               | 4.9 <sub>85</sub>  | 4.7 <sub>95</sub>  |
| 300 x 63   | 5.2                              | 5.0 | 4.7 | 4.5 | 4.2 | 4.0 | 6.4                                  | 6.2 | 5.8 | 5.6               | 5.3                | 5.2 <sub>75</sub>  |
| 2/300 x 45 | 5.6                              | 5.4 | 5.1 | 4.9 | 4.7 | 4.5 | 7.0                                  | 6.7 | 6.3 | 6.1               | 5.8                | 5.6                |
| 2/300 x 63 | 6.0                              | 5.8 | 5.5 | 5.2 | 5.0 | 4.9 | 7.5                                  | 7.2 | 6.8 | 6.5               | 6.3                | 6.1                |
| 360 x 45   | 5.5                              | 5.3 | 4.9 | 4.7 | 4.5 | 4.3 | 6.8                                  | 6.6 | 6.2 | 5.8 <sub>85</sub> | 5.4 <sub>100</sub> | 5.1 <sub>110</sub> |
| 360 x 63   | 5.9                              | 5.7 | 5.4 | 5.1 | 4.9 | 4.7 | 7.3                                  | 7.1 | 6.7 | 6.4               | 6.1 <sub>75</sub>  | 5.9 <sub>85</sub>  |
| 2/360 x 45 | 6.4                              | 6.2 | 5.8 | 5.6 | 5.3 | 5.2 | 8.0                                  | 7.7 | 7.2 | 6.9               | 6.6                | 6.4                |

| e-beam     | Wall Supporting Tile Roof        |     |     |     |                   |                   |                                      |                    |                    |                    |                    |                    |
|------------|----------------------------------|-----|-----|-----|-------------------|-------------------|--------------------------------------|--------------------|--------------------|--------------------|--------------------|--------------------|
|            | Maximum Single Span <sup>1</sup> |     |     |     |                   |                   | Maximum Continuous Span <sup>2</sup> |                    |                    |                    |                    |                    |
|            | Roof Load Width (m)              |     |     |     |                   |                   |                                      |                    |                    |                    |                    |                    |
|            | 1.8                              | 2.4 | 3.6 | 4.8 | 6.0               | 7.2               | 1.8                                  | 2.4                | 3.6                | 4.8                | 6.0                | 7.2                |
|            | Span Opening (m) – see D33       |     |     |     |                   |                   |                                      |                    |                    |                    |                    |                    |
| 200 x 45   | 2.8                              | 2.6 | 2.3 | 2.2 | 2.0               | 1.9               | 3.7                                  | 3.5                | 3.1                | 2.9                | 2.7 <sub>100</sub> | 2.5 <sub>100</sub> |
| 200 x 63   | 3.1                              | 2.9 | 2.6 | 2.4 | 2.3               | 2.1               | 4.2                                  | 3.9                | 3.5                | 3.2                | 3.0                | 2.9                |
| 2/200 x 45 | 3.5                              | 3.3 | 2.9 | 2.7 | 2.5               | 2.4               | 4.6                                  | 4.4                | 3.9                | 3.6                | 3.4                | 3.2                |
| 2/200 x 63 | 3.9                              | 3.6 | 3.3 | 3.0 | 2.8               | 2.7               | 5.0                                  | 4.8                | 4.4                | 4.0                | 3.8                | 3.6                |
| 240 x 45   | 3.3                              | 3.1 | 2.8 | 2.6 | 2.4 <sub>40</sub> | 2.3 <sub>45</sub> | 4.5                                  | 4.2                | 3.8                | 3.5 <sub>100</sub> | 3.2 <sub>115</sub> | 3.0 <sub>125</sub> |
| 240 x 63   | 3.7                              | 3.5 | 3.1 | 2.9 | 2.7               | 2.6               | 4.9                                  | 4.6                | 4.2                | 3.9                | 3.6                | 3.4 <sub>100</sub> |
| 2/240 x 45 | 4.2                              | 3.9 | 3.5 | 3.2 | 3.0               | 2.9               | 5.3                                  | 5.0                | 4.7                | 4.3                | 4.1                | 3.9                |
| 2/240 x 63 | 4.6                              | 4.3 | 3.9 | 3.6 | 3.4               | 3.2               | 5.7                                  | 5.4                | 5.0                | 4.8                | 4.5                | 4.3                |
| 300 x 45   | 4.2                              | 3.9 | 3.5 | 3.2 | 3.0 <sub>50</sub> | 2.9 <sub>55</sub> | 5.3                                  | 5.0                | 4.5 <sub>105</sub> | 4.0 <sub>120</sub> | 3.8 <sub>140</sub> | 3.5 <sub>160</sub> |
| 300 x 63   | 4.6                              | 4.3 | 3.9 | 3.6 | 3.4 <sub>40</sub> | 3.2 <sub>45</sub> | 5.7                                  | 5.4                | 5.0                | 4.7 <sub>100</sub> | 4.5 <sub>115</sub> | 4.3 <sub>135</sub> |
| 2/300 x 45 | 5.0                              | 4.8 | 4.4 | 4.0 | 3.8               | 3.6               | 6.2                                  | 5.9                | 5.5                | 5.2                | 4.9                | 4.6 <sub>95</sub>  |
| 2/300 x 63 | 5.4                              | 5.1 | 4.8 | 4.5 | 4.2               | 4.0               | 6.7                                  | 6.4                | 5.9                | 5.6                | 5.4                | 5.1                |
| 360 x 45   | 4.9                              | 4.6 | 4.2 | 3.9 | 3.6 <sub>55</sub> | 3.4 <sub>65</sub> | 6.0                                  | 5.6 <sub>100</sub> | 5.0 <sub>120</sub> | 4.5 <sub>140</sub> | 4.2 <sub>160</sub> | 3.9 <sub>175</sub> |
| 360 x 63   | 5.3                              | 5.0 | 4.6 | 4.3 | 4.1 <sub>45</sub> | 3.8 <sub>50</sub> | 6.5                                  | 6.2                | 5.8 <sub>100</sub> | 5.4 <sub>115</sub> | 5.2 <sub>140</sub> | 5.0 <sub>160</sub> |
| 2/360 x 45 | 5.7                              | 5.4 | 5.0 | 4.8 | 4.5               | 4.3 <sub>40</sub> | 7.1                                  | 6.8                | 6.3                | 5.9                | 5.5 <sub>100</sub> | 5.1 <sub>110</sub> |

**1** For single span, bearing shall not be less than 35mm at end supports except where indicated otherwise by a subscript.

**2** For continuous span, bearing shall not be less than 35mm at end supports and 90mm at intermediate supports unless indicated otherwise by a subscript. The subscript value indicates the required bearing at the intermediate support and where this is greater than 100mm, the bearing at the corresponding end supports shall not be less than one third the subscript value.

## SERVICES HOLE GUIDE

Holes for the installation of ducts, service pipes and electrical conduits may be cut through e-joist webs as per the following limitations on their locations.

- 1 In general larger holes should be positioned closer to mid-span.
- 2 Minimum spacing between holes must be at least 300mm or twice the diameter or length of the largest opening.
- 3 40mm diameter holes can be drilled anywhere within the web provided they are a minimum of 300mm centers apart.
- 4 Maximum of three holes per span – holes less than 75mm can be excluded from this total.
- 5 It is recommended that the position of square, rectangular and round holes be at the mid-height of the joist. The minimum edge clearance from the top and bottom LVL flange is 5mm.
- 6 All holes to be cut carefully – do not overcut.
- 7 Do not cut, notch, plane or drill into flanges (other than as per D14 for support locations only).
- 8 Web hole locations can be interpolated for intermediate spans.

**Diagram D34:**  
service hole locations

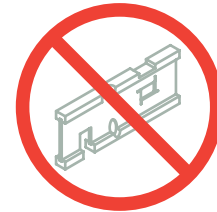
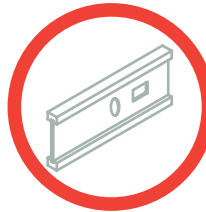
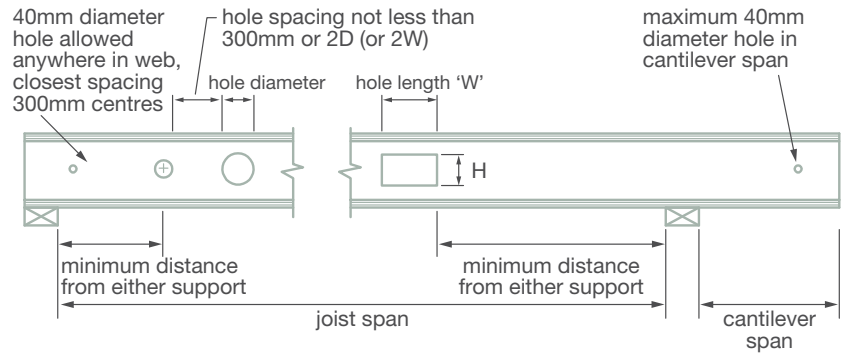

**SERVICES  
HOLE  
GUIDE**

 Floor Joist  
Applications in Domestic  
Residences Only

| e-joist<br>Section<br>Code | Installed<br>Span | Circular or Square Holes                                |      |      |      |      |      |      |
|----------------------------|-------------------|---|------|------|------|------|------|------|
|                            |                   | ø75   | ø100 | ø125 | ø150 | ø175 | ø200 | ø250 |
|                            |                   | Minimum distance from support<br>– external or internal |      |      |      |      |      |      |
| ej20045                    | 3.0               | 0.30  | 0.30 | 0.51 | NS   | NS   | NS   | NS   |
|                            | 4.0               | 0.30  | 0.41 | 1.01 | NS   | NS   | NS   | NS   |
|                            | 5.0               | 0.30  | 0.91 | 1.51 | NS   | NS   | NS   | NS   |
| ej20063                    | 3.0               | 0.30  | 0.30 | 0.51 | NS   | NS   | NS   | NS   |
|                            | 4.0               | 0.30  | 0.41 | 1.01 | NS   | NS   | NS   | NS   |
|                            | 5.0               | 0.30  | 0.91 | 1.51 | NS   | NS   | NS   | NS   |
| ej20090                    | 3.5               | 0.30  | 0.30 | 0.51 | NS   | NS   | NS   | NS   |
|                            | 4.5               | 0.30  | 0.41 | 1.01 | NS   | NS   | NS   | NS   |
|                            | 5.5               | 0.30  | 0.91 | 1.51 | NS   | NS   | NS   | NS   |
| ej24045                    | 3.5               | 0.30  | 0.30 | 0.30 | 0.40 | NS   | NS   | NS   |
|                            | 4.5               | 0.30  | 0.30 | 0.30 | 0.90 | NS   | NS   | NS   |
|                            | 5.5               | 0.30  | 0.30 | 0.80 | 1.40 | NS   | NS   | NS   |
| ej24063                    | 4.0               | 0.30  | 0.30 | 0.30 | 0.66 | NS   | NS   | NS   |
|                            | 5.0               | 0.30  | 0.30 | 0.55 | 1.16 | NS   | NS   | NS   |
|                            | 6.0               | 0.30  | 0.45 | 1.05 | 1.66 | NS   | NS   | NS   |
| ej24090                    | 4.5               | 0.30  | 0.30 | 0.32 | 0.92 | NS   | NS   | NS   |
|                            | 5.5               | 0.30  | 0.30 | 0.82 | 1.42 | NS   | NS   | NS   |
|                            | 6.5               | 0.30  | 0.72 | 1.32 | 1.92 | NS   | NS   | NS   |
| ej30045                    | 4.5               | 0.30  | 0.30 | 0.30 | 0.30 | 0.30 | 0.66 | NS   |
|                            | 5.5               | 0.30  | 0.30 | 0.30 | 0.30 | 0.60 | 1.16 | NS   |
|                            | 6.5               | 0.30  | 0.30 | 0.30 | 0.45 | 1.06 | 1.66 | NS   |
| ej30063                    | 4.5               | 0.30  | 0.30 | 0.30 | 0.30 | 0.30 | 0.67 | NS   |
|                            | 5.5               | 0.30  | 0.30 | 0.30 | 0.30 | 0.56 | 1.17 | NS   |
|                            | 6.5               | 0.30  | 0.30 | 0.30 | 0.46 | 1.06 | 1.67 | NS   |
|                            | 7.0               | 0.30  | 0.30 | 0.30 | 0.71 | 1.31 | 1.92 | NS   |
| ej30090                    | 5.0               | 0.30  | 0.30 | 0.30 | 0.30 | 0.33 | 0.93 | NS   |
|                            | 6.0               | 0.30  | 0.30 | 0.30 | 0.30 | 0.83 | 1.48 | NS   |
|                            | 7.0               | 0.30  | 0.30 | 0.30 | 0.73 | 1.33 | 1.93 | NS   |
|                            | 7.5               | 0.30  | 0.30 | 0.37 | 0.98 | 1.58 | 2.18 | NS   |
| ej36063                    | 5.0               | 0.30  | 0.30 | 0.30 | 0.30 | 0.30 | 0.30 | 0.68 |
|                            | 6.0               | 0.30  | 0.30 | 0.30 | 0.30 | 0.30 | 0.30 | 1.18 |
|                            | 7.0               | 0.30  | 0.30 | 0.30 | 0.30 | 0.30 | 0.48 | 1.68 |
|                            | 7.5               | 0.30  | 0.30 | 0.30 | 0.30 | 0.30 | 0.73 | 1.93 |
| ej36090                    | 5.0               | 0.30  | 0.30 | 0.30 | 0.30 | 0.30 | 0.30 | 0.69 |
|                            | 6.0               | 0.30  | 0.30 | 0.30 | 0.30 | 0.30 | 0.30 | 1.19 |
|                            | 7.0               | 0.30  | 0.30 | 0.30 | 0.30 | 0.30 | 0.49 | 1.69 |
|                            | 8.0               | 0.30  | 0.30 | 0.30 | 0.30 | 0.38 | 0.99 | 2.19 |

| Rectangular Holes                                       |              |              |              |              |
|---|--------------|--------------|--------------|--------------|
| Height x Width (mm)                                     |              |              |              |              |
| 125<br>x 250  | 150<br>x 300 | 175<br>x 350 | 200<br>x 400 | 250<br>x 500 |
| Minimum distance from support<br>– external or internal |              |              |              |              |
| 0.51  | NS           | NS           | NS           | NS           |
| 1.01  | NS           | NS           | NS           | NS           |
| 1.51  | NS           | NS           | NS           | NS           |
| 0.51  | NS           | NS           | NS           | NS           |
| 1.01  | NS           | NS           | NS           | NS           |
| 1.51  | NS           | NS           | NS           | NS           |
| 0.51  | NS           | NS           | NS           | NS           |
| 1.01  | NS           | NS           | NS           | NS           |
| 1.51  | NS           | NS           | NS           | NS           |
| 0.30  | 0.40         | NS           | NS           | NS           |
| 0.30  | 0.90         | NS           | NS           | NS           |
| 2.17  | 2.24         | NS           | NS           | NS           |
| 0.30  | 0.66         | NS           | NS           | NS           |
| 0.55  | 1.16         | NS           | NS           | NS           |
| 2.48  | 2.53         | NS           | NS           | NS           |
| 0.32  | 0.92         | NS           | NS           | NS           |
| 0.82  | 1.42         | NS           | NS           | NS           |
| 1.32  | 1.92         | NS           | NS           | NS           |
| 0.30  | 0.30         | 0.65         | 0.91         | NS           |
| 1.27  | 1.66         | 1.82         | 1.91         | NS           |
| 2.90  | 2.90         | 2.92         | 2.91         | NS           |
| 0.30  | 0.30         | 0.30         | 0.67         | NS           |
| 0.30  | 0.96         | 1.39         | 1.58         | NS           |
| 2.39  | 2.53         | 2.60         | 2.64         | NS           |
| 3.16  | 3.17         | 3.17         | 3.17         | NS           |
| 0.30  | 0.30         | 0.33         | 0.93         | NS           |
| 0.30  | 0.30         | 0.83         | 1.48         | NS           |
| 0.30  | 0.73         | 1.33         | 1.93         | NS           |
| 0.30  | 0.98         | 1.58         | 2.18         | NS           |
| 0.30  | 0.30         | 0.30         | 0.30         | 0.68         |
| 0.30  | 0.30         | 0.38         | 1.00         | 1.47         |
| 0.30  | 1.40         | 1.91         | 2.15         | 2.39         |
| 0.30  | 2.31         | 2.56         | 2.70         | 2.85         |
| 0.30  | 0.30         | 0.30         | 0.30         | 0.69         |
| 0.30  | 0.30         | 0.30         | 0.30         | 1.19         |
| 0.30  | 0.30         | 0.30         | 0.49         | 1.69         |
| 0.30  | 0.30         | 0.30         | 1.33         | 2.19         |

- Distance from support is measured from the face of the support to the centre of a circular hole or to the edge of a square or rectangular hole.
- Web hole locations can be interpolated for intermediate spans.
- NS – Not Suitable.

## E-JOIST SPECIFICATION

### e-joist

|                               |        |              |
|-------------------------------|--------|--------------|
| <b>Dimensional Tolerances</b> | Length | -0mm, + 20mm |
|                               | Depth  | -1mm, + 2mm  |
|                               | Width  | -1mm, + 1mm  |

|                              |                       |
|------------------------------|-----------------------|
| <b>Adhesive (flange/web)</b> | Phenolic Formaldehyde |
|------------------------------|-----------------------|

|                 |   |
|-----------------|---|
| <b>Branding</b> | Each e-joist is branded at least once with the product name for identification and evidence of compliance with manufacturing control standards. |
|-----------------|---|

|                |  |
|----------------|--|
| <b>Storage</b> | e-joists must only be stacked in the upright position to avoid any damage during storage or handling. Only stack on level bearers (3.0m spacing max) providing a ground clearance of at least 150mm. e-joists are not to be placed over ponded water and are to be kept as dry as practicable. |
|----------------|--|

Do not stack e-joists on the flat.

### flange

|               |           |  |
|---------------|-----------|--|
| <b>Veneer</b> | Thickness | Constant but can vary between 3.2mm and 4.8mm<br>Sustainably sourced timbers |
|               | Species   | Outer 2 plies are scarf jointed  |
|               | Joints    | Inner plies – scarf and/or butt jointed                                      |

|                         |                                |
|-------------------------|--------------------------------|
| <b>Moisture Content</b> | 8% – 15% (at time of despatch) |
|-------------------------|--------------------------------|

|                |                                       |
|----------------|---------------------------------------|
| <b>Density</b> | 650 kg/m <sup>3</sup> (approximately) |
|----------------|---------------------------------------|

|                 |   |
|-----------------|---|
| <b>Adhesive</b> | Phenolic – AS2754.1:2016 - Adhesives for timber and timber products; Adhesives for manufacture of plywood and laminated veneer lumber (LVL) |
|-----------------|---|

|             |   |
|-------------|---|
| <b>Bond</b> | Type A – AS/NZS2098.2:2012 - Methods of tests for veneer and plywood; Bond quality of plywood (chisel test) |
|-------------|---|

|                                   |   |
|-----------------------------------|---|
| <b>LVL Manufacturing Standard</b> | AS/NZS4357 Structural Laminated Veneer Lumber |
|-----------------------------------|---|

|                    |     |
|--------------------|-----|
| <b>Joint Group</b> | JD4 |
|--------------------|-----|

|               |  |
|---------------|--|
| <b>Finish</b> | Unsanded faces, sawn edges and arrised edges |
|---------------|--|

### web

|                 |  |
|-----------------|--|
| <b>Material</b> | Orientated Strand Board (OSB) or Strandboard |
|-----------------|--|

|                         |                                |
|-------------------------|--------------------------------|
| <b>Moisture Content</b> | 8% – 15% (at time of despatch) |
|-------------------------|--------------------------------|

|                 |   |
|-----------------|---|
| <b>Adhesive</b> | Phenolic – AS2754.1:2016 - Adhesives for timber and timber products; Adhesives for manufacture of plywood and laminated veneer lumber (LVL) |
|-----------------|---|

|             |   |
|-------------|---|
| <b>Bond</b> | Type A – AS/NZS2098.2:2012 - Methods of tests for veneer and plywood; Bond quality of plywood (chisel test) |
|-------------|---|

|                                   |            |
|-----------------------------------|------------|
| <b>Web Manufacturing Standard</b> | EN300:2006 |
|-----------------------------------|------------|

|                                 |   |
|---------------------------------|---|
| <b>Safety Data Sheets (SDS)</b> | Please refer to the Wesbeam website at <a href="http://www.wesbeam.com">www.wesbeam.com</a> to download the SDS sheets for LVL, OSB or Strandboard. |
|---------------------------------|---|

## GENERAL NOTES

- 1 Specified floor joist spans are independent of flooring type and are therefore suitable for a range of flooring products including: particleboard flooring, plywood flooring or strip flooring.
- 2 Heavier floor loads (floor mass >40kg/m<sup>2</sup>, live loads for floor joists >1.5kPa and live loads for cantilever balconies >2.0kPa) requires special consideration – refer to Wesbeam technical support.
- 3 During construction, no one is to walk on or load joists until all blocking, rimbeams, temporary bracing, hangers or nails are installed.
- 4 Temporary battens must be used during construction. Joists must be restrained at a maximum of 2.5m centres with battens (70 x 20mm min.) fixed back to points of rigidity.
- 5 A minimum of 35mm bearing is required unless noted otherwise – as per D2.
- 6 All joists to be installed vertically plumb and kept straight between supports.
- 7 All joists require lateral support at end bearings – as per D5, D6 and D7.
- 8 Internal load bearing walls are to be supported by continuous e-joist blocking as per D8.
- 9 Joist hanger installation to be as per manufacturer's product literature. Incorrect installation can lead to unsafe or unsatisfactory performance.
- 10 Nailing Specification - all nails to be flat head unless otherwise specified.

| Connection  | Nailing Requirement  | Detail Ref |
|---|--|------------|
| Joist to bearing plate  | 2 x ø3.15 x 65   | D3         |
| Web stiffeners  | See table  | D4         |
| Rimboard – skew nail to bearing plate<br>Rimboard to joist top and bottom flanges<br>Flooring to Rimboard | ø3.15 x 65 nails at 150mm crs,<br>or ø4.5 x 75 nails at 300mm crs<br>1 x ø3.15 x 65 nail to each flange<br>as per flooring requirements of<br>AS1684 | D5         |
| e-joist blocking – skew nail<br>to bearing plate  | ø3.15 x 65 nails at 150mm crs  | D6         |
| Flooring to e-joist blocking  | as per flooring requirements<br>of AS1684  | D6         |
| Rimjoist – skew nail to bearing plate   | ø3.15 x 65 nails at 150mm crs  | D7         |
| Rimjoist to joist top and bottom flanges  | 1 x ø3.15 x 75 nail  | D7         |
| Flooring to Rimjoist  | as per flooring requirements<br>of AS1684  | D7         |
| Joist hangers   | See tables   | D11        |
| Adjacent non-loadbearing<br>cantilvered joist   | 2 rows ø3.15 x 65 nails at 50mm<br>crs and min nail group each end   | D21        |
| Nested non-loadbearing<br>cantilvered joist   | 2 rows ø3.15 nails at 150mm<br>crs and min nail group each end<br>Single joist – 50mm long<br>Double joist – 100mm long                              | D24        |
| Loadbearing cantilever<br>Reinforcement/flange  | ø2.8 x 50 nails at 100mm crs   | D29        |
| Reinforcement/stiffener   | Minimum of 5 x ø3.15 nails –<br>45 and 51mm flanges – 75mm<br>long 63 and 90mm flanges –<br>90mm long  | D29        |



## NOTES

## NOTES

## NOTES



© Wesbeam Pty Limited  
ABN 89 004 268 017  
WESB0372 January 2020

**WESTERN AUSTRALIA**

190 Pederick Road  
Neerabup | WA | 6031

**T** 08 9306 0400

**F** 08 9306 0444

**E** sales.wa@wesbeam.com

**QUEENSLAND**

3 Bult Drive  
Brendale | QLD | 4500

**T** 07 3385 3900

**F** 07 3385 3911

**E** sales.qld@wesbeam.com

**SOUTH AUSTRALIA**

200 Cavan Road  
Dry Creek | SA | 5094

**T** 08 8214 8500

**E** sales.sa@wesbeam.com

**VICTORIA**

Rear | 35 Greens Road  
Dandenong South | VIC | 3175

**T** 03 8782 9500

**E** sales.vic@wesbeam.com

**NEW SOUTH WALES**

8-24 Dunheved Circuit  
St Marys | NSW | 2760

**T** 02 8856 8400

**E** sales.nsw@wesbeam.com

**DESIGN CENTRE**

Suite B/524 Milton Road  
Toowong | QLD | 4066

**T** 1300 356 460

**E** design@wesbeam.com